

OPERATING INSTRUCTIONS

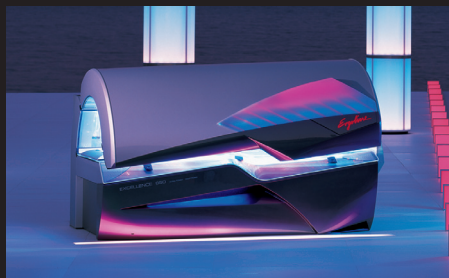
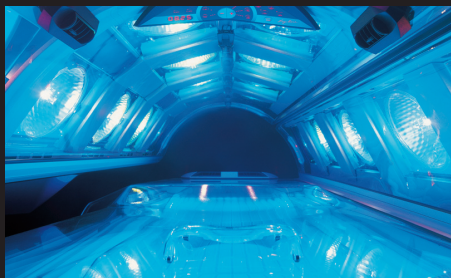

EXCELLENCE 850

Ergoline

Ergoline Excellence

800881 / Index „c“ / us / 06.2004

Operating Instructions

Excellence 850 Ultra Power Tempronic

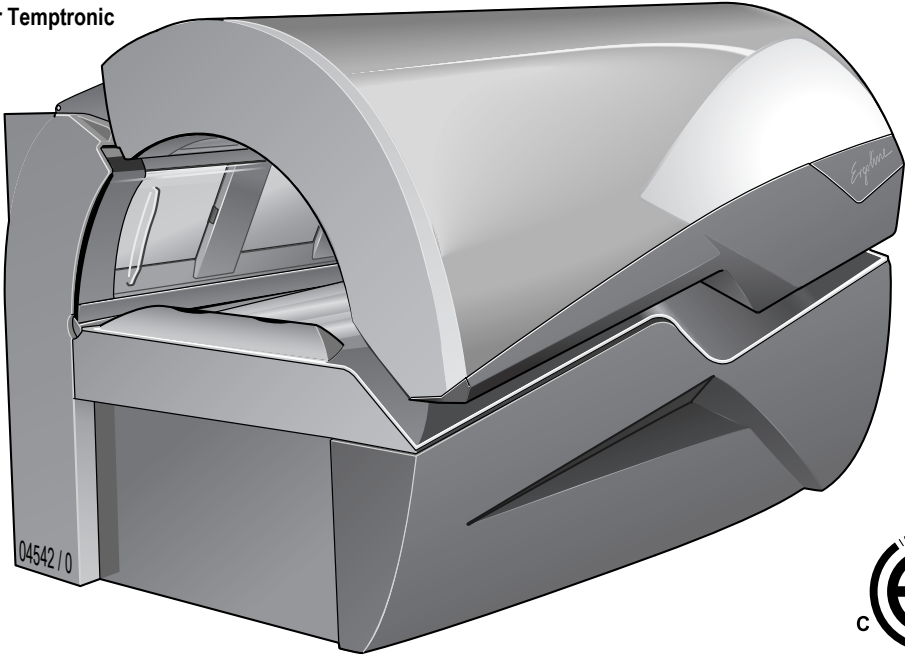

Identify your tanning device

For contact with customer service, please write down the device number of your tanning device.

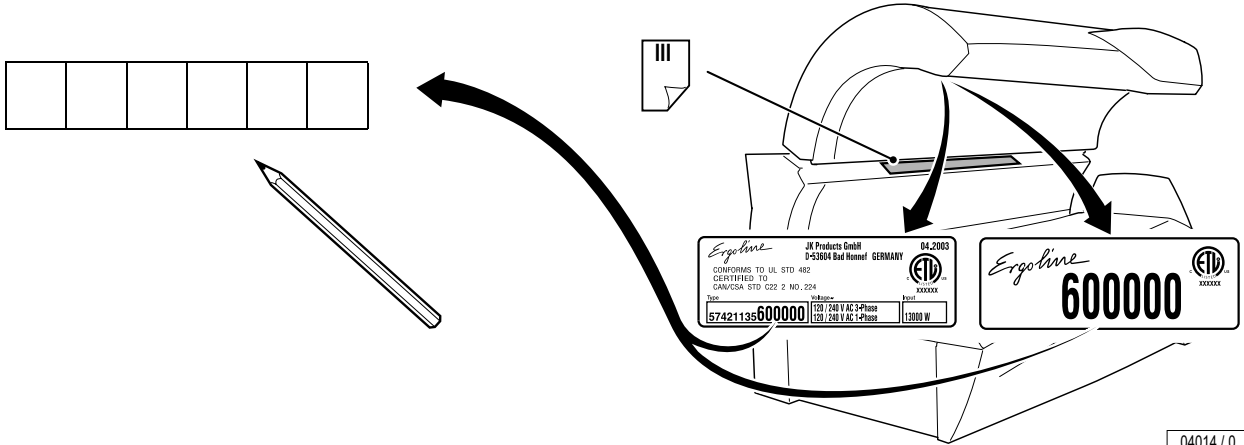

Global Service Division
#1 Walter Kratz Drive
Jonesboro, Arkansas 72401

04014 / 0



(800) 445 0624

DANGER ULTRAVIOLET RADIATION

Follow instructions. Avoid over-exposure as with natural sunlight. Over-exposure can cause eye and skin injury and allergic reactions. Repeated exposure may cause premature aging of the skin and skin cancer.

Maximum Tanning Time is 12 Minutes

| Skin Type | Recommended Exposure Schedule | | | | |
|----------------|-----------------------------------|-----------------------------------|------------------------------------|-------------------------------------|------------------------------------|
| | Week 1 1st - 3rd Treatments | Week 2 4th - 6th Treatments | Week 3 7th - 10th Treatments | Week 4 11th - 15th Treatments | Weekly Subsequent Treatments |
| II - Fair | 2 Min. | 5 Min. | 8 Min. | 10 Min. | 12 Min. |
| III - Average | 2 Min. | 5 Min. | 8 Min. | 10 Min. | 12 Min. |
| IV - Brown | 2 Min. | 7 Min. | 10 Min. | 12 Min. | 12 Min. |
| V - Dark Brown | 2 Min. | 7 Min. | 10 Min. | 12 Min. | 12 Min. |

WEAR PROTECTIVE EYEWEAR! Failure to do so may result in severe burns or long term injury to the eyes.

Certain medications or cosmetics may increase your sensitivity to the ultraviolet radiation. Consult a physician before using sunlamps if you are using medication, have a history of skin problems or believe yourself to be especially sensitive to sunlight. If you do not tan in the sun, you are unlikely to tan from the use of this product.

This unit utilizes UVA lamps. Replace only with Ergoline VHP 12 PREMIUM 160W Turbo Power, Ergoline VHP 25W Power (shoulder-/ neck-tanner) and Ergoline ultra 520W C12645 (high pressure) or recognized equivalents. To obtain recommended exposure at a minimum distance of 1/2" (13mm) measured with a standard ruler, lie on acrylic surface of lounge and lower canopy. Canopy will stop at the correct distance from lounge acrylic surface.

Warning: The use of any other position may result in overexposure!

Tanning can begin on a regular basis. An appearance of tanning normally appears after a few exposures and maximizes after four (4) weeks of exposure following the recommended exposure schedule for skin type. In order to provide for maintenance of a tan a maximum of two (2) weekly 12 minute sessions is recommended from the fifth week onward.

Use protective eyewear (Part No. Schmerler 2255 Red or recognized equivalents) when equipment is on. Read and follow instruction booklet before using this product. To avoid electrical shock during maintenance disconnect power from unit.

Part No: 801642



Note:
Description of skin types see Page 17.

04874 / 0

"This product is in conformity with performance standards for sunlamp products under CFR21 Part 1040."

Foreword

Dear Customer,

The Ergoline device you have purchased is a technically advanced and powerful microcomputer control system. Your device was manufactured with the greatest care and precision. It went through numerous quality and safety checks in order to guarantee trouble-free, safe operation. But you too may make a significant contribution to your long-term satisfaction with your device. Following the tips and instructions in the instruction manual will ensure you enjoyment and pleasure with your device.

In case of any questions, we are always at your disposition¹⁾.

Your sincerely

Sun Ergoline

- Read and observe the information in this instruction manual. This will enable you to prevent accidents and provide you with a reliable device ready for use.
- Always observe the local and federal regulations and legal requirements as well as the valid environmental protection regulations.

1) ☎ (800) 643 0086

Table Of Contents

| | | | |
|--|-------------------------|--|-------------------------|
| Intended use | 8 | Regulating face tanner | 25 |
| Danger of damage to persons | 8 | Regulating body tanner. | 26 |
| Meaning of symbols | 10 | Switching shoulder tanner off and on | 27 |
| Guidelines | 13 | Regulating Temptronic ¹⁾ (air condition). | 28 |
| Export | 13 | Regulating body cooling | 29 |
| Equipment | 13 | Regulating facial cooling. | 30 |
| Accessories | 13 | Voice Guide | 31 |
| Product information | 14 | Listening to INFO texts | 32 |
| Maintenance and care | 14 | Selecting music channel | 33 |
| Cleaning | 15 | Adjusting volume | 34 |
| Environmental protection information | 16 | Technical Data | 35 |
| General tanning instructions | 16 | Maintenance | Fold-out page 37 |
| Skin types | 17 | Maintenance, overview | 37 |
| Operation | 19 | Maintenance intervals, installed lamps and order numbers | 38 |
| Operating table | Fold-out page 19 | Cleaning/replacing UV low-pressure lamps in sunbed base | 44 |
| Overview | 19 | Cleaning/replacing UV low-pressure lamps in neck tanner | 46 |
| Accessories | 21 | Cleaning/replacing UV low-pressure lamps in shoulder tanner | 48 |
| Settings during start-up | 23 | Cleaning/replacing interior lighting | 50 |
| Terminate tanning session | 23 | | |
| Running time of accent lights. | 24 | | |
| IR function | 24 | | |

1) optional

Table Of Contents

| | |
|---|----------------------------|
| Cleaning/replacing UV high-pressure lamps/filter panels in side section | 52 |
| Cleaning/replacing UV high-pressure lamps/filter panels in canopy | 55 |
| Cleaning/replacing accent lights in canopy | 58 |
| Cleaning/replacing accent lights in frontpanel | 61 |
| Cleaning filters in sunbed base | 63 |
| Cleaning/replacing filter mats in canopy | 65 |
| Cleaning/replacing filter mats in shoulder tanner | 66 |
| Air Condition: cleaning/replacing filter mat, emptying condensate container | 68 |
| Presettings | 70 |
| Changing presettings with the control panel | 70 |
| Changing presettings with a hand-held unit | 72 |
| Troubleshooting | 75 |
| Index | 79 |
| Warranty | 81 |
| Timer operation | see separate manual |



Note:

Technical changes are reserved with respect to the illustrations and specifications in this instruction manual. Reprinting and reproduction, in whole or in part, of this manual is only permitted with our previous written approval and with specification of the source.

Safety notes

Description of warning signs

Danger notes, damage to persons:



Type and source of danger, e.g. "DANGER – High voltage!"

DANGER!

Description of the consequences, e.g. "You can be killed or injured by an electric shock!"

Countermeasures:

- Disconnect device from power supply before opening.
- Do not reach into the inside or change lamps with the device switched on.

Warning notes, damage to persons:



Type and source of danger, e.g. "Warning – hot surface!"

WARNING!

Description of the consequences, e.g. "You can burn your hand (skin, face)!"

Countermeasures:

- Do not touch the lamps and nearby surfaces.
- Wait until lamps and surfaces have cooled down.

Caution notes, property damage:



CAUTION!

The word "CAUTION" with this label points out that danger for devices, materials and the environment can be expected here.

Important information:



Note:

This symbol does not identify safety notes, but states information for a better understanding of the processes.

Intended use

The tanning device is intended exclusively for cosmetic tanning of the human skin:

- This device is used for tanning one adult person at a time.
- The user wears suitable eye protection that blocks UV radiation during tanning.

Any other use shall be considered improper. The manufacturer cannot be held liable for damage or injuries resulting from improper use. The operator bears the sole risk for this.

The proper use also includes compliance with the manufacturer's instructions, operating, maintenance and regulation conditions. The device may only be operated, maintained and repaired by persons familiar with these tasks and that have been informed of the dangers involved.

Important notes for the studio operator

- As the operator you are responsible for informing users on possible risks during tanning.
- All danger and safety labels attached to the device must be observed! Do not remove them!
- No safety equipment (e.g. panel switch) may be removed or deactivated which can impair the safe operation of the device!
- The device may only be operated in proper condition!

Danger of damage to persons



DANGER!

DANGER – High voltage!

You can be killed or injured by an electric shock!

Assembly and electrical connection must comply with the national and local regulations.

– Assembly, installation, upgrading or repair of the device may only be carried out by specially trained and instructed personnel.



WARNING!

Warning – ultraviolet radiation!"

Unprotected tanning may result in eye injuries and eye diseases.

The unprotected eye can become inflamed on the surface, and in certain cases the retina can be damaged by excessive radiation. Cataracts can form after frequently repeated exposure to radiation.

– Inform users to close their eyes during tanning and use the included protective goggles that block UV (Order No. 84592¹⁾).

1) Global Service Division – see page II.

Danger of damage to persons



Warning – ultraviolet radiation!

WARNING! As with natural sunlight, overexposure can cause eye and skin injury and allergic reactions. Repeated exposure may cause premature aging of the skin and skin cancer. Wear protective eye wear; failure to may result in severe burns or long-term injury to eyes.

Occasionally, persons using the tanning device will experience a slight reddening of the skin – usually in small patches – after the second or third session. This redness is often accompanied by an itching sensation. This may be nothing more than a heat “rash” caused by heat from the lamps within the device. It is generally very limited and caused by constant contact of the skin with the acrylic surface. It should go away within approximately 24 hours and should not reappear. This rashing can be lessened or prevented by applying moisturizer lotion to the affected area after the tanning session is completed.

- Follow instructions.
- The time between two tanning sessions must be at least 24 hours!
- Increasing tanning also requires an extension of the exposure time (= radiation time) or after a certain degree of tanning has been achieved, a further intensification is not possible. However, the radiation time may not be extended as desired within the scope of the permissible radiation doses! Therefore, only a certain degree of final tanning dependent on the skin type can be achieved without endangering your health.

– Inform users about proper tanning – see page 16.



Warning – ultraviolet radiation!

WARNING! Danger of long-term consequences.

- Nursing infants and small children through age 7 years may not use this device.
- The following applies to minors under the age of 18 years: Only use tanning devices in agreement with a parent or guardian, or after consulting a physician.
- While there is no immediate clinical evidence of UVA exposure and its effects upon expectant mothers, it is strongly advised that expectant mothers be discouraged from using the tanning unit.

Please read and observe ...

Meaning of symbols

Symbols for Description, Operation and Maintenance

General Symbols



Inform Customer Service



Ergoline key



Phillips screwdriver



Do not touch, hot surface!



Low-pressure lamp(s)



UV low-pressure lamp(s)



Starter for low-pressure lamp(s)

General Symbols



UV high-pressure lamp(s)



Accent lamp



Filter panels



Cleaning and disinfectant agents











Part/article number (for orders)





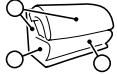



Operation



Display of tanning time

Please read and observe ...

| | |
|--|---|
|  | Display of run-on time (fan run-on) |
|  | Fault display (example), see Page 75 |
|  | Display of Info Track 1 (from 1-17) |
|  | Display of Music Channel 1 (Channel 1) Factory setting: 1 channel Customer service can set up to 7 channels |
|  | Display when adjusting volume |
|  | Description |
|  | Accent lighting |
|  | Press button |
|  e.g. 2s | Press button for 2 seconds |

| | |
|---|---|
|  | Duration: 3 minutes |
|  | Loudspeaker |
|  | Headphone connection |
| Technical data |  |
| Maintenance |  |
|  | Caution, safety switch! |
|  | Unscrew/release screw |
|  | Tighten/lock screw |
|  | Unscrew/release screw with a screwdriver |

Please read and observe ...



Tighten/lock screw with a screwdriver



Suction cup



Cleaning



Replacing



Clean or replace depending on soiling



Draining



Visual inspection



Air Condition



Filter/filter mat



Continuation of work steps
on next page



End of work step

Presettings



Troubleshooting



Guidelines

This device was built according to UL STD 482, certified to CAN/CSA STD C22.2 2 No. 224.



CAUTION – Air inflow and outflow

Do not change, obstruct or block the air inflow and outflow area to the device or make any unauthorized changes to the device. The manufacturer shall bear no liability for damage or injuries resulting from such actions.

Export

We would like to point out that the devices are exclusively intended for use in the US and Canada, and may not be exported to other countries and operated there! The manufacturer shall assume no liability whatsoever in case of non-observance! We explicitly emphasize that high liability risks may occur for the exporter an/or the operator in case of non-observance.

Equipment

The equipment of the devices differs depending on the model.

In this instruction manual all standard and optional components/functions are taken into account which must be observed during operation and/or when performing maintenance.

The control panel is also affected by the differing equipment: Only those buttons are visible that can be operated, i.e. the corresponding function must be part of the equipment of the device.

Accessories

Some accessory parts are taken into account in the maintenance schedule beginning on Page 39, however this does not automatically mean that your device is provided with this equipment (e.g. Tempronic).

An overview of the possible accessories is provided in the sales documentation.

Please read and observe ...

Product information

Acrylic glass panels

The acrylic glass panels for the tanning devices are produced of acrylic glass developed especially for this application. The acrylics used are characterized by a particularly high UV permeability and resistance, as well as an easy-care, hygienic surface that is gentle to the skin.

The acrylic glass panels are formed to their shapes for the specific devices in a technically complex production process. Despite state-of-the-art production know-how, the presence of minor spots, air bubbles or streaks in the acrylic panels is unavoidable. In addition, hairline cracks can occur on the bed surface during operation.

These occurrences are material-dependent and are unavoidable in processing, however have no significant effect on the utility value and can therefore not be recognized as defects.



CAUTION!

Cosmetics or sun screen products must be removed prior to tanning as they can cause damage (e.g. cracks on the surface) when used continuously.

Maintenance and care



DANGER!

Extreme danger! High voltage!

During maintenance work there is a danger of touching live parts and receiving a fatal electrical shock.

- Disconnect device from power supply before opening – also see Page 37.
- Do not reach behind covers, do not open the device and do not replace lamps with the device switched on.

Maintenance and care play a major role in deciding whether the device meets the requirements placed on it in a satisfactory manner. The compliance with the specified maintenance intervals and the careful conducting of the maintenance and care work are therefore absolutely necessary – see Page 39 ff.

The current operating hours of the parts requiring maintenance can be displayed in the Presetting mode – see Page 70 ff.

Remount any protective devices (e.g. filter panels) after completing work.



CAUTION!

Only use original spare parts of the same type or compatible parts! The use of other parts voids the conformity! Any liability is excluded in case of damage or injury proven to be the result of the use of non-original spare parts.

Please read and observe ...

Cleaning

Acrylic glass surfaces



CAUTION!

Do not rub with a dry cloth – danger of scratching!
For fast, hygienic proper cleaning of acrylic glass surfaces, use the specially developed fast disinfectant cleaner Anti-fect®.

Concentrated disinfectants or solvents (e.g. Lysoform, ethyl alcohol or other liquids containing alcohol) may never be used for cleaning. Other unsuitable cleaning agents that cause damage due to chemical reactions may also not be used!

Plastic surfaces

For cleaning the other plastic surfaces, it is best to use warm water and a leather cloth. Never use aggressive cleaning agents containing alcohol, e.g. the commercially available Sagrotan, or essential oils. These may lead, in the long run, to damages not covered by the warranty.

During cleaning a slight discoloration of the leather cloth by the rubber seals must be expected for production-related reasons.



Note:

Prevent damage to the acrylic glass and plastic surfaces. Remove rings, watches, bracelets etc. before the start of cleaning work.

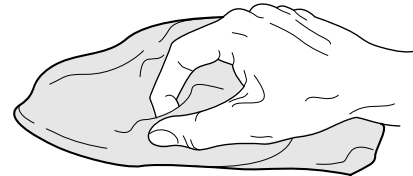
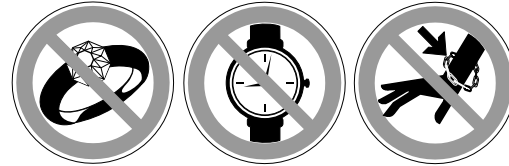

02756 / 0

Please read and observe ...

Environmental protection information

Environmental Declaration – The JK Corporate Group

The JK corporate group is subject to the strict regulations of EC Directive 761/2001 and the standard DIN ISO 14001, and undergoes regular internal and external environment audits performed by trained auditors.

Environmental regulations – disposal of lamps

UV low-pressure lamps and UV high-pressure lamps contain fluorescent materials and other waste containing mercury.

According to the national waste disposal laws and in accordance with the municipal waste regulations, proof must be provided of the proper disposal of UV lamps.

Your local environmental agency will be happy to assist you with the disposal of UV lamps.

General tanning instructions

Who can get a tan?

Anyone who also gets a tan in natural sunlight. Persons with sensitive skin even tan more pleasantly and with fewer worries, as the radiation dosage can be exactly defined with sunbeds.

Certain drugs – particularly those that produce photosensitivity – may cause individuals under the influence of this type drug to experience adverse effects and those people should avoid exposure to UV sources of all kinds. Doctors will advise people taking these drugs to possible adverse effects.

The speed and intensity with which someone tans are dependent on the skin type and the individual melanin quantity in the skin. No two individual skin tones are the same. A tan to one person may be different to another and treatment length may vary.

What is Melanin?

The brownish pigment produced by special cells in the base layer of your skin determines the individual's tan. As the skin is exposed to the ultraviolet light, the melanin is activated and combines with protein cells that rise to the skin's surface, thus producing a tan. The amount of melanin in your body determines how quickly and dark you tan. The more melanin produced and exposure time an individual has, the faster and deeper the individual will tan.

Please read and observe ...



Note:

The tan produced by the tanning unit is a deep, rich “Cosmetic” tan. However, regardless of how dark an individual may tan on his system, it will not provide adequate protection against overexposure to natural sunlight or UVB tanning systems.

Which tanning times are recommended?

Although there is virtually no reason to worry about sunburn with the UV tanning method, some consideration should initially be given to individual skin sensitivity.



Danger of skin injuries and skin diseases!

DANGER! Although UVA radiation is relatively harmless compared to natural sunlight, excessive tanning times can lead to the skin becoming red and to burns.

- Comply with the recommended tanning times, see Page III.

Once you have a tan, 1 to 2 tanning sessions per week are usually sufficient to maintain it.

Should you use sun screen?

No! It is recommended to not use sun screens, oils or lotions intended for outdoor use. Cosmetic sun screens with a sun protection factor (SPF) are intended to filter out the sun's aggressive rays. However, the light of

our sunbeds only contains extremely small quantities of comparable rays, making this kind of protection unnecessary. On the contrary, the skin should be thoroughly cleaned and dried before each sunbath. Many facial makeups have oil bases and should be removed prior to a session.

Adequate ventilation of the room or booth housing the tanning device is required for proper and comfortable operation. Your tanning device will perform best at the ambient temperature of 75 °F to 90 °F.

It is recommended that, following a tanning session, a skin moisturizer be applied. This promotes a smoother, more even looking tan.

Skin types

For the recommended exposure schedule (see page III):

Skin type II:

This is the individual that usually burns easily and severely, tans minimally or lightly and peels.

Skin type III:

Often referred to as “Average” complexion, burns moderately and tans about average.

Skin type IV:

This individual burns minimally, tans easily and above average with each exposure.

Skin type V:

This individual's system rarely burns, tans easily and substantially.

Please read and observe ...

Operation

Mandatory reading

Always read and follow all instructions for proper usage prior to using any tanning device. The operating instructions included with this device must always be followed to prevent possible injuries or to reduce them to a minimum.

Inform users

- to use provided UV-blocking protective eyewear whenever the equipment is energized.
- to follow the exposure schedule in accordance with their skin type. Failure to do so may result in overexposure.

A tanning system is not a toy. You cannot vary the strength of the lamps in your unit.

Should you have any questions regarding the proper use of your tanning system, contact Sun Ergoline at:

☎ 1-800-643-0086

8:00 a.m. to 5:00 p.m. (CST)



WARNING – ultraviolet radiation!

WARNING! Danger of skin injuries and skin diseases!
– The sunbed may never be used when a filter panel is missing or damaged, or the timer is defective!



Note:

When describing the operation, the tanning device is often shown with the canopy open. During tanning the canopy must always be closed.

No proper operation is possible with the canopy open.

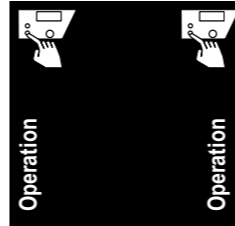

Please open this fold-out page.

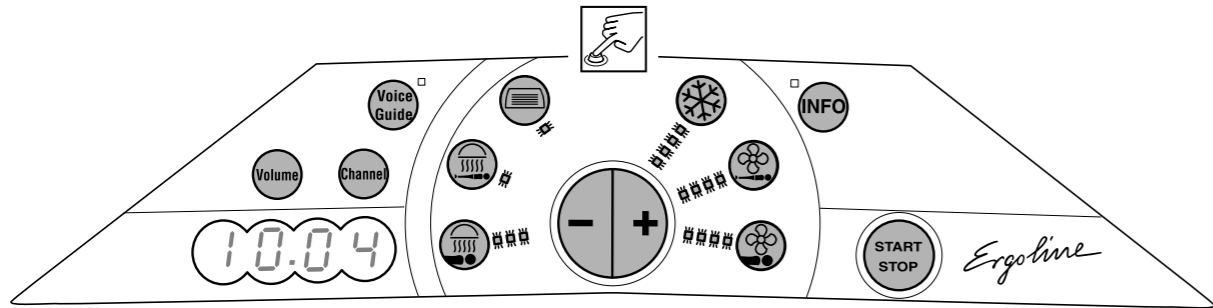

04876 / 1

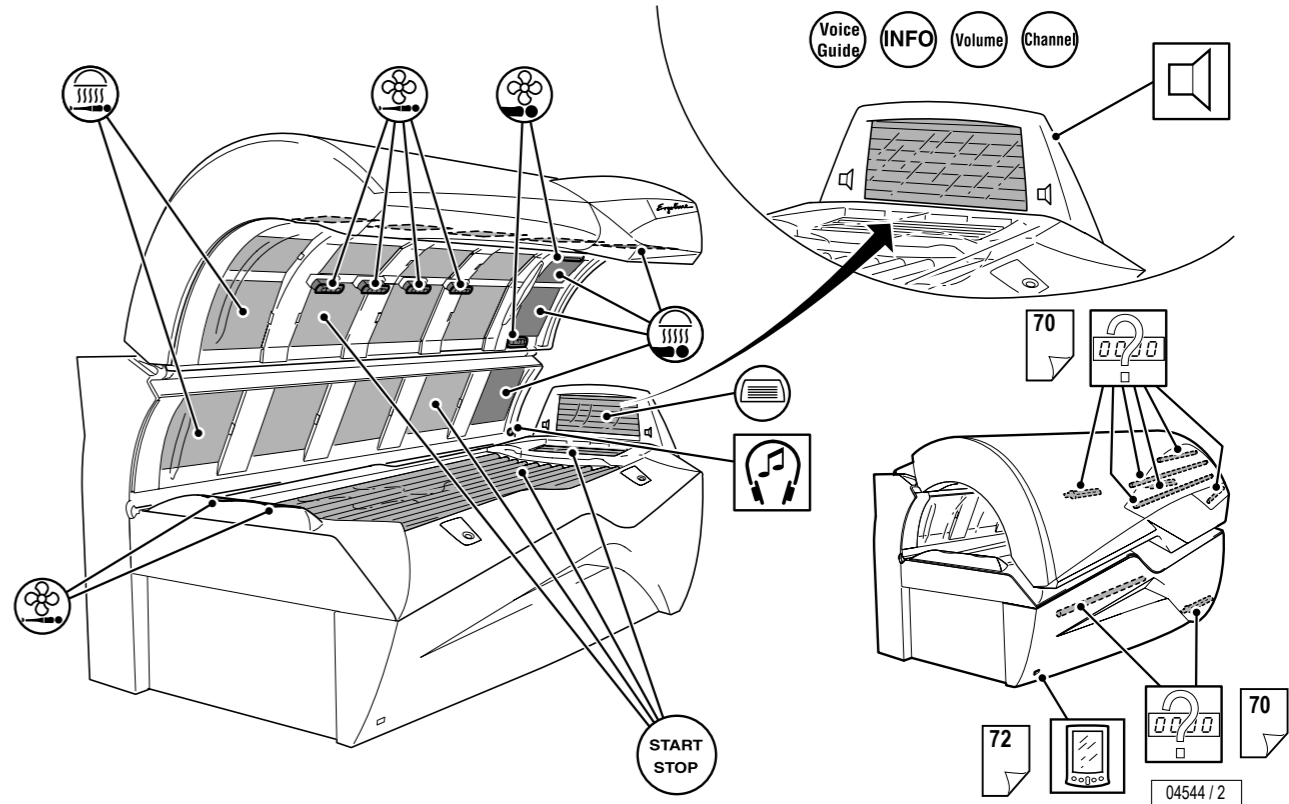
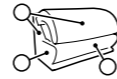

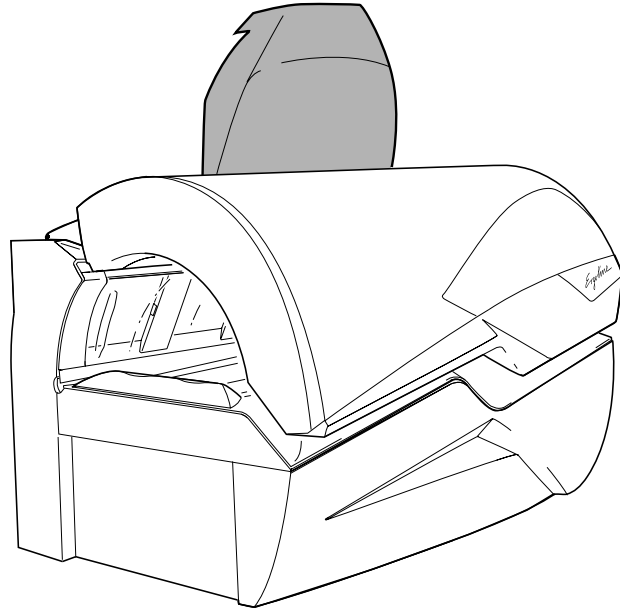
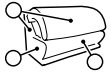

04543 / 0

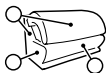

Tanning

Start and end of tanning

The device is started automatically with an internal or external timer and automatically stopped after the preselected time. The fan continues to run for approx. 3 minutes (fan delay) to sufficiently cool the device.



Note:

Timer instructions: see separate manual.

Preparation time

Before the UV lamps automatically go on, you have a few minutes to prepare yourself. During the preparation time you can switch on the UV lamps at any time by pressing the START/STOP button.

- Remove your clothes and all jewelry.
- Remove make-up and other cosmetics.
- Remove glasses. Contact lenses can be worn under the protective goggles.
- Put on the protective goggles.
- Lie down on the bed surface.
- Close the canopy.

Depending on the controller, the tanning device starts up after a short time automatically. The tanning device is operating when the UV lamps are on and the fans are running.

If the device fails to start up when you have closed the canopy:

- Press START/STOP to start tanning.

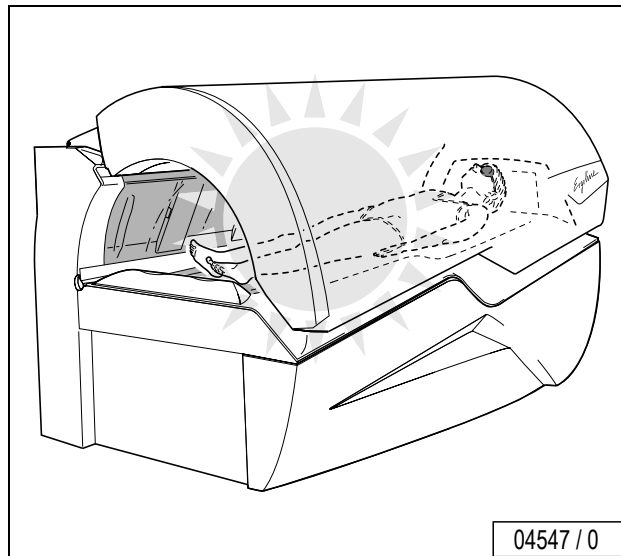

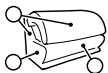

Settings during start-up

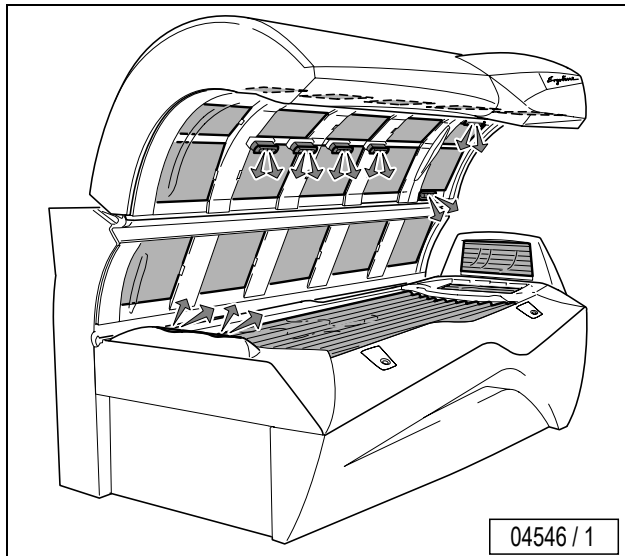

To interrupt tanning session

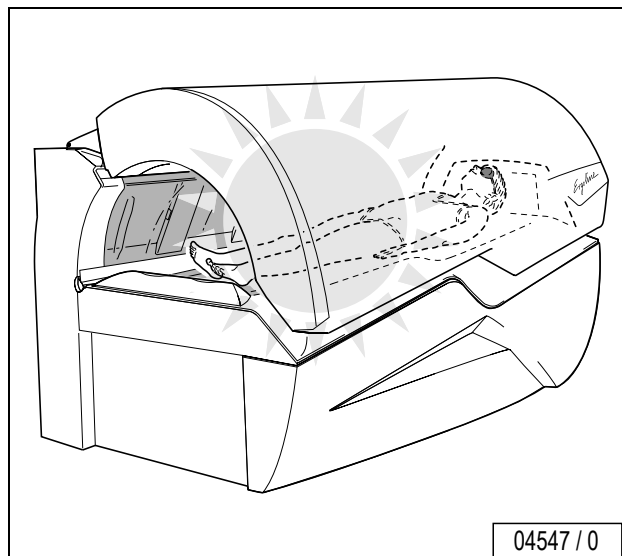

The tanning time can be interrupted during tanning by switching off the UV lamps:

- Press START/STOP for three (3) seconds to pause or stop tanning.
- Press START/STOP again for three (3) seconds to restart the lamps.



Operation



Running time of accent lights

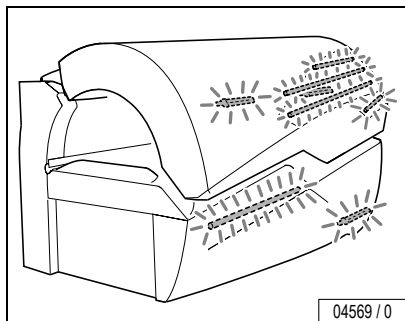

04569 / 0

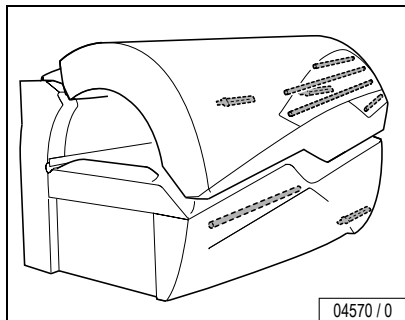
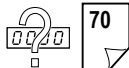

04570 / 0

The accent lights are running during and after the tanning session and are automatically switched off at the end of the predefined time.

The running time of the accent lights in the Standby mode can be changed with the presettings – see from Page 70 on.

IR function

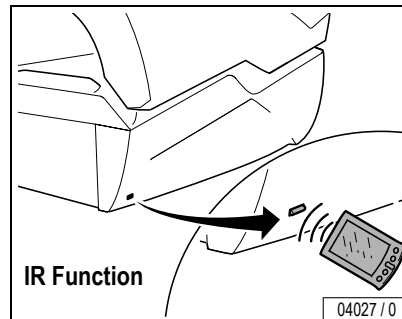
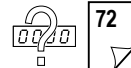

IR Function

04027 / 0





Face tanner

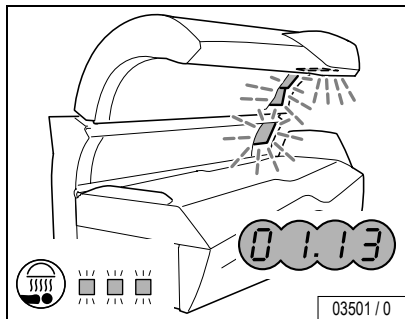

Switching the face tanner OFF:

– Press button  for two (2) seconds.

Switching on face tanner again:

– Press button again. It takes approx. one (1) minute until the face tanners reach their full output.

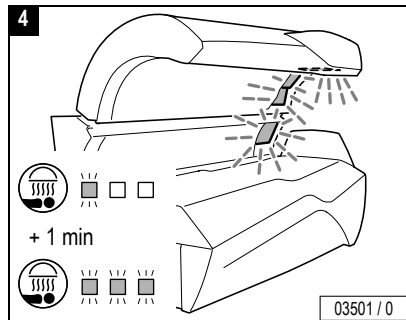
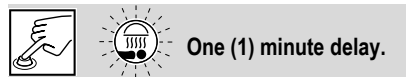
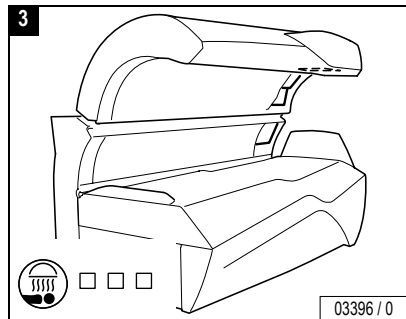
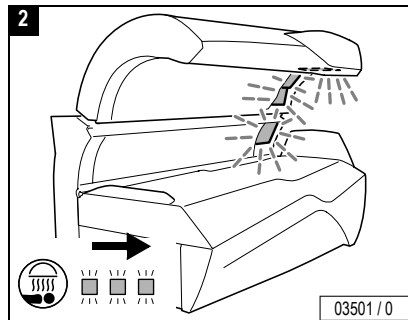
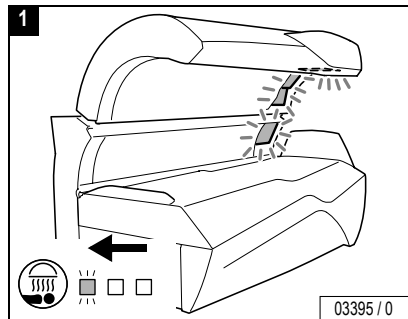



Operation



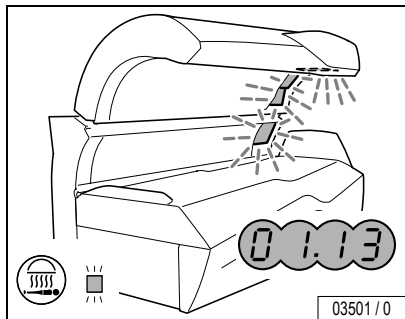

Body tanner



- Press button .
- While the button flashes, press the plus or minus button to change the intensity of the body tanner.

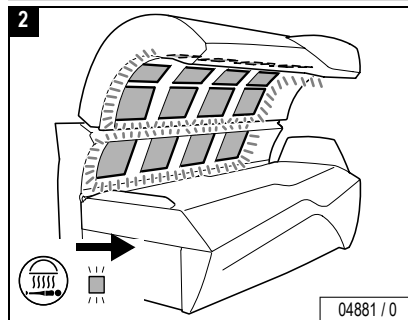
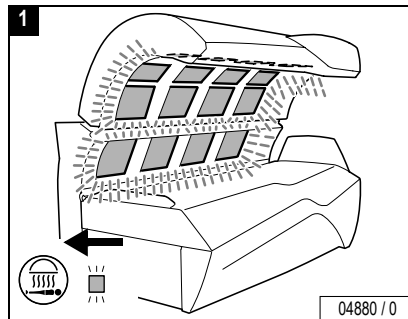



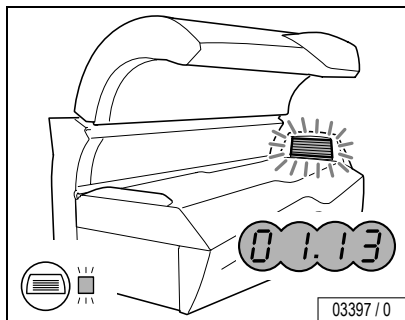

Shoulder tanner



Switching the shoulder tanner OFF:

- Press button .
- While the button flashes, press the minus button for two (2) seconds to switch the shoulder tanner off.

Switching the shoulder tanner on again:

- Press button .
- While the button flashes, press the plus button to switch the shoulder tanner on.



Press for two (2) seconds.

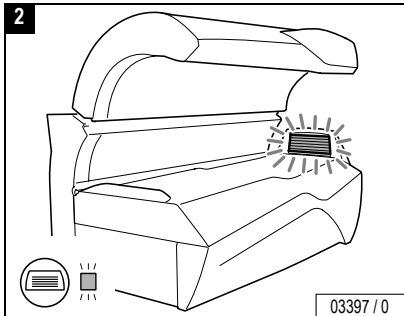
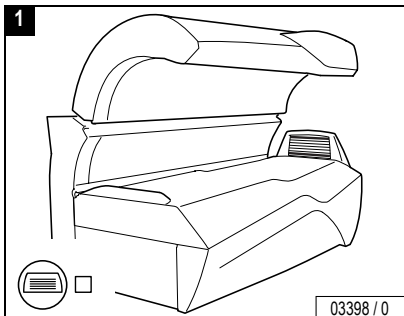

Operation





Temptronic – Adjust coolness

Operation

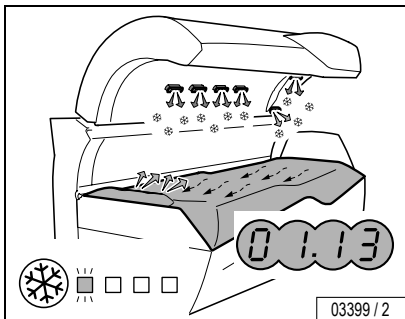

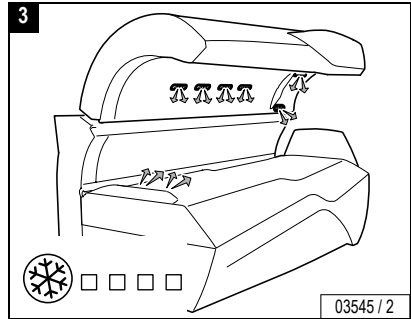
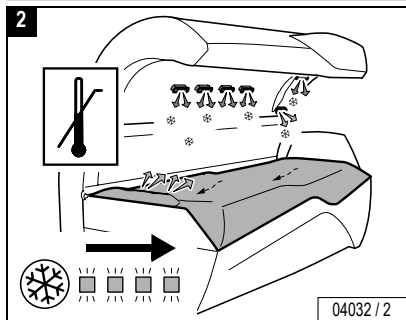
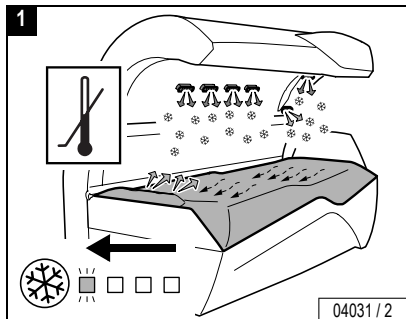

- During start-up the second of 8 levels is active
- Press button  (Temptronic).
 - While the button flashes, press the plus or minus button to change the cooling intensity.



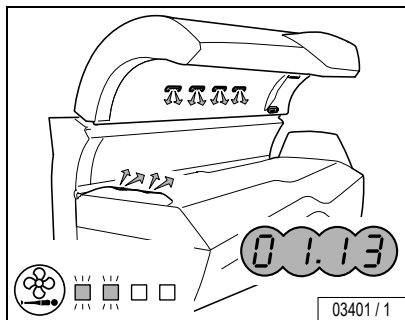

Surround cooling body nozzles – Adjust speed



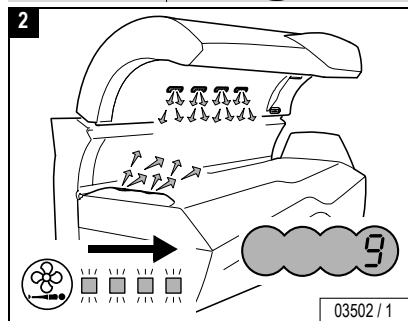
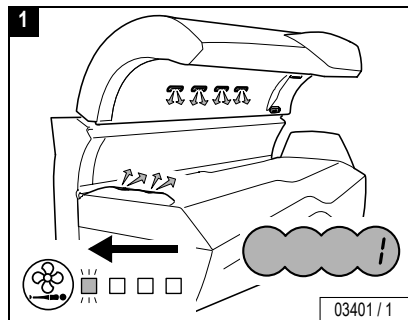

- Press button .
- While the button flashes, press the plus or minus button to change the intensity of the air stream.



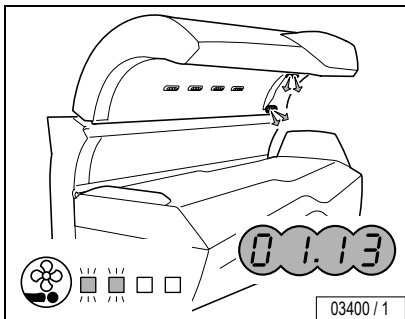

Surround cooling head nozzles – Adjust speed



- Press button .
- While the button flashes, press the plus or minus button to change the intensity of the air stream.

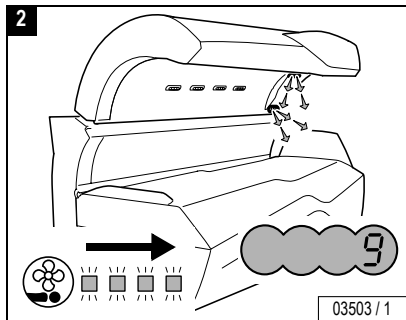
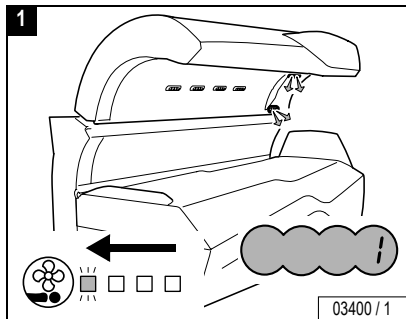



Voice Guide

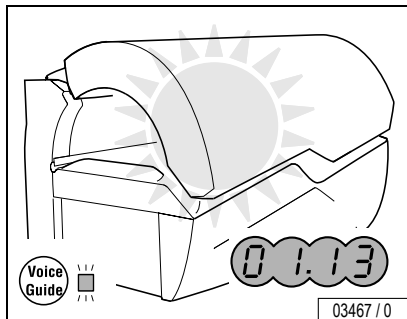

When Voice Guide is switched on, you hear an explanation of the button function each time a button is pressed.

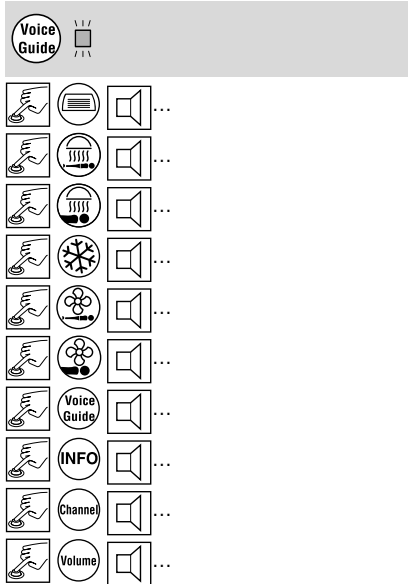
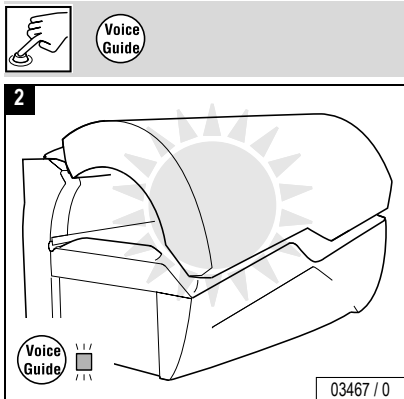
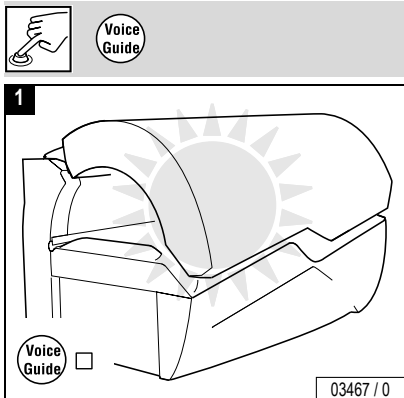

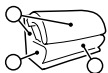

INFO

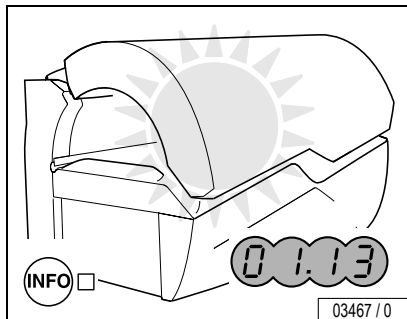

When you press the **INFO** button, general texts on tanning are played.

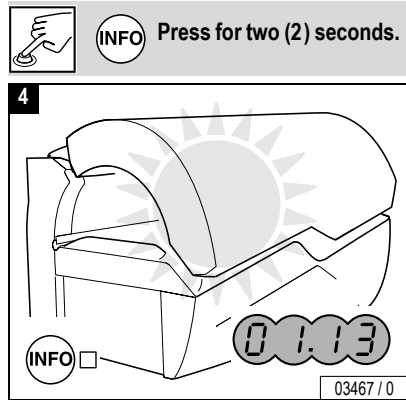
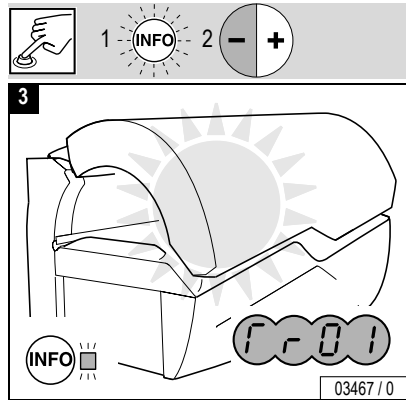
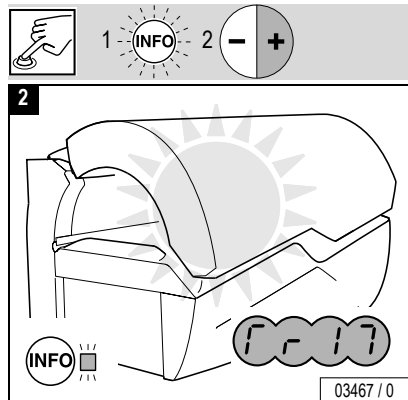
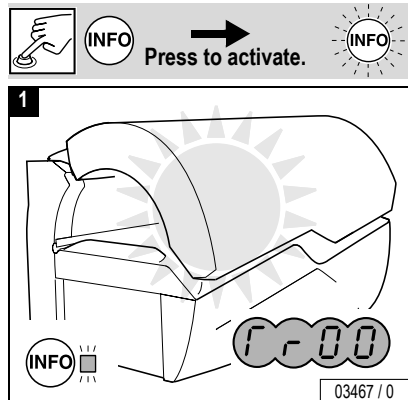

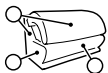

Channel

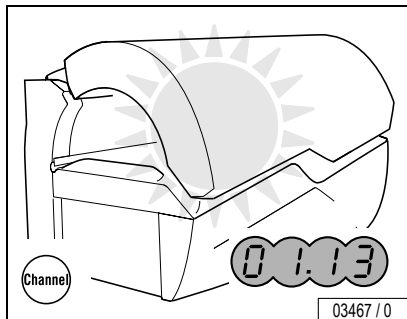

03467 / 0

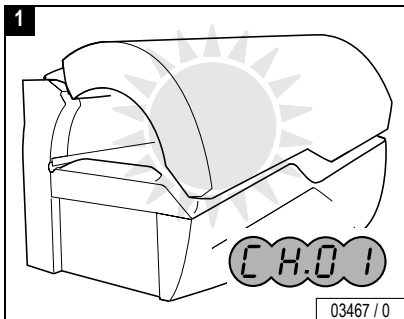
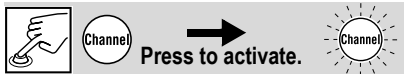

03467 / 0

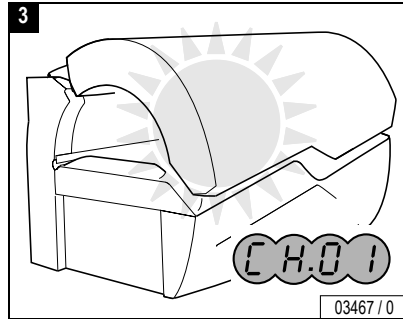
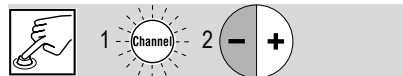

03467 / 0

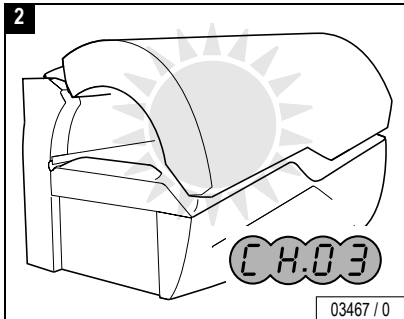
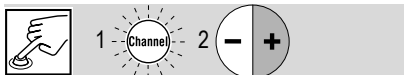

03467 / 0

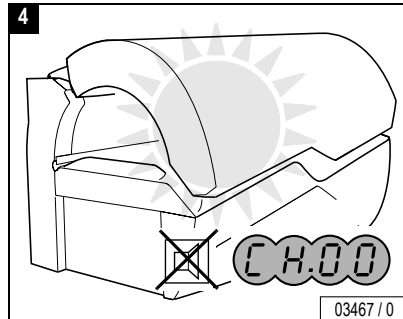
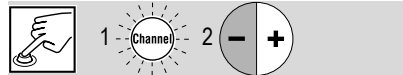

03467 / 0

– Press button .

– While the button flashes, press the plus or minus button to select a channel.

CH.00 means: no Channel selected, there is no sound, music is “OFF”.



Operation





Volume

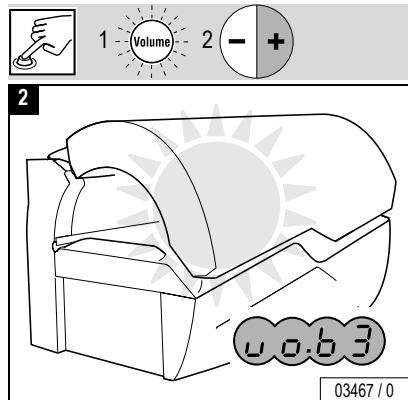
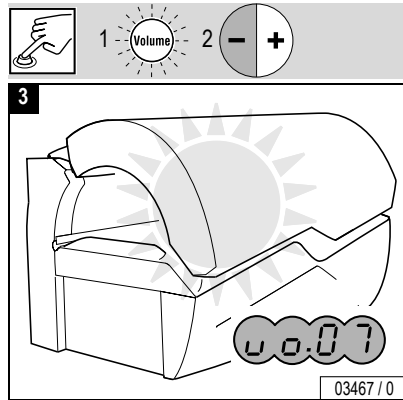
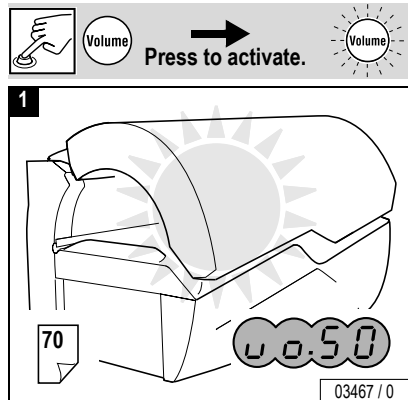
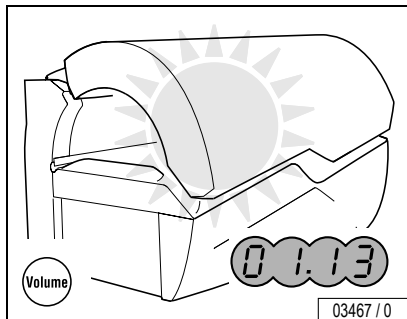



- Press button .
- While the button flashes, press the plus or minus button to change the volume.





Technical data

| | |
|--------------------------|---|
| Model: | Ergoline Excellence 850 Turbo Power |
| Rated power consumption: | 21,000 W  |
| Rated voltage: | 230 V |
| Rated frequency: | 60 Hz |
| Rated fusing: | 90 amp 3-pole |
| Conformity mark: |  |

**Powerinput 3-pole
(max. 90 amp)
230V AC 60 Hz**

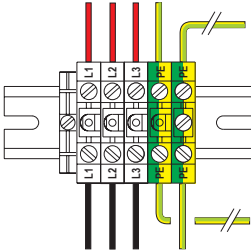

⚠ DANGER USA
HAZARDOUS VOLTAGE.
Contact will cause
electric shock!
Disconnect and lock out
power before servicing.

⚠ DANGER F
TENSION DANGEREUSE.
Tout contact entraînera une décharge
électrique !
Débrancher et sécuriser l'alimentation
électrique avant de procéder à l'entretien.

JK - 801047 "a" / 01.2004

04605 / 1



Technical data



Bed tolerance in room

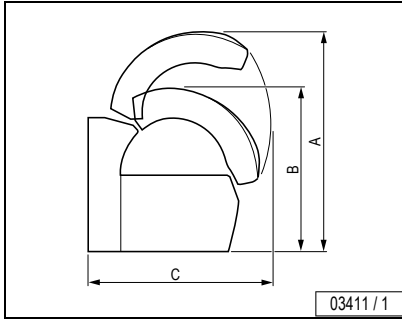

| | |
|-------------|----------------|
| A = 1830 mm | A = 72 1/16 in |
| B = 1373 mm | B = 54 1/16 in |
| C = 1565 mm | C = 61 5/8 in |
| D = 2110 mm | D = 83 1/16 in |
| E = 2323 mm | E = 91 7/16 in |
| F = 850 mm | F = 33 7/16 in |

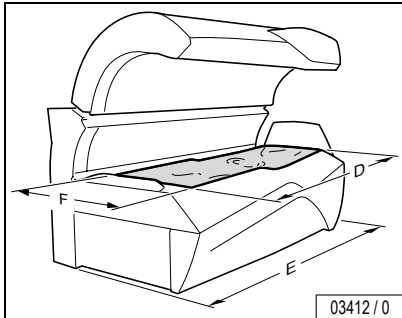

Maximum room temperature / Humidity

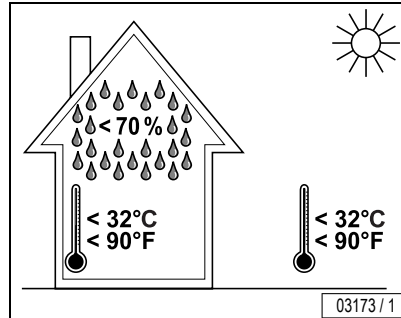

< 70 %

< 32°C
< 90°F

< 32°C
< 90°F

Maximum permissible load

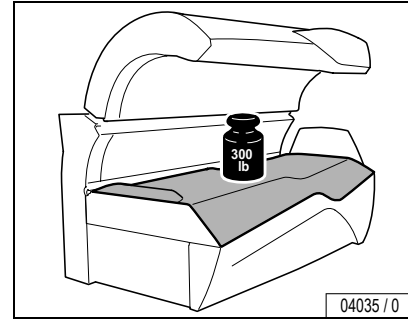

Warning – possible breakage of the acrylic panel!

WARNING!

Severe cuts from glass and burns from hot lamps may result.

- Only one adult person is allowed at the same time.
- People that weigh more than 300 lbs must not use the device at all.



Maintenance

De-energize device and secure against being switched on again



DANGER!

Extreme danger!

If work is to be performed on the devices, they must be de-energized. That means that all live lines must be switched off.

Switching off the device alone is insufficient, as certain points may remain energized. Therefore, switch off fuses before performing any work and – if possible – remove them.



04049 / 0

- In case of circuit breakers which cannot be screwed out, a strip of adhesive tape may be applied over the actuation lever with the wording “Do not switch, danger!”.

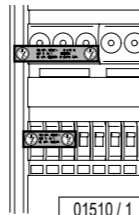

01510 / 1

A prohibition sign with the text:

- “Work in progress!”
- “Place:
- “Sign may only be removed by:

must always be securely mounted immediately.



01511 / 1



DANGER!

Extreme danger!

Prohibition signs must not be hung on or touch live parts.

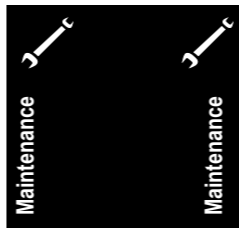

Please open this fold-out page.



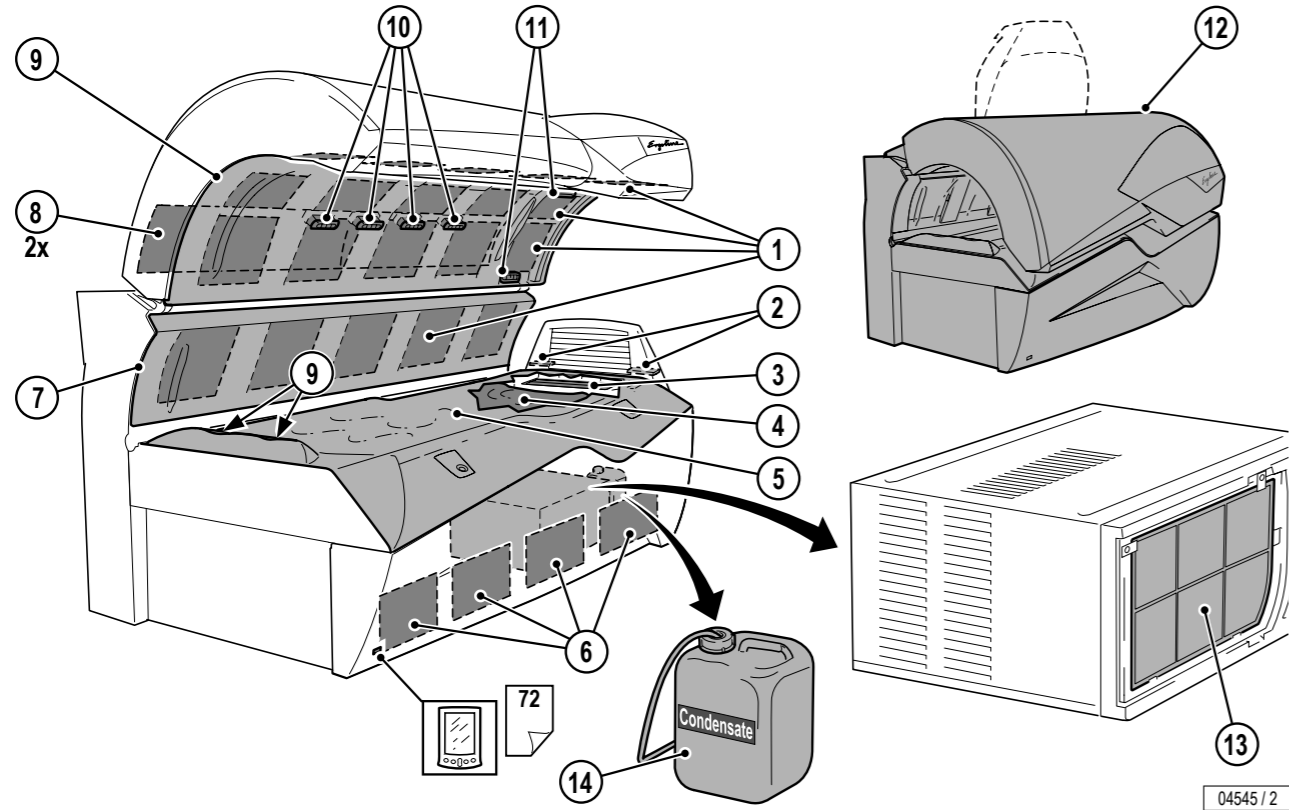
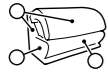

















Scheduled cleaning

| | | |
|-----------------------------|-----------|---|
| | | |
| | 5 | i Note: Clean after every use. |
| Clean if necessary! | 1 12 14 | |
| | 12 | |
| | 4 | |



Scheduled maintenance – filters

|  |  | |   |  |  |  |
|---|---|---|--|---|---|---|
|  /50 h | ⑥ 4 x |  | | 51 937 |  | 63 |
| | ⑧ 2 x |  | | 800 601 |  | 65 |
| | ⑬ 1 x |  | | 51 975 |  | 68 |
| | ② 2 x |  | | 800 278 |  | 66 |









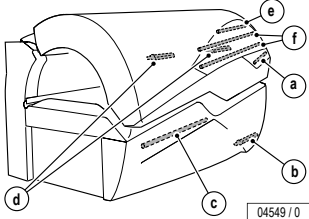





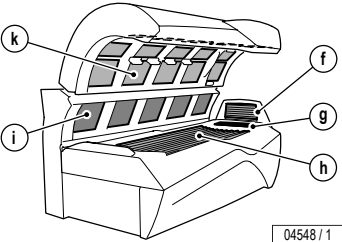

Scheduled maintenance – accent lights

Maintenance

| | Excellence 850 Ultra Power Tempronic | | | |
|--|---|--------------------------------------|-------|----|
| |  | a) 1 x white 8 W | 11839 | 58 |
| | | b) 1 x blue 9 W | 12262 | 61 |
| | | c) 1 x blue 30 W | 12377 | 61 |
| | | d) 2 x blue 9 W | 12262 | 50 |
| | | e) 2 x white Aquastar F 36/174 36 W | 12158 | 58 |
| | | f) 1 x white Aquastar F 18/174 18 W | 12156 | 58 |
| | | a) c) 5 x S10 | 10047 | |



Scheduled maintenance – UV lamps, starters

|  | Excellence 850 Ultra Power Temptronic |  |  |  | |
|--|--|---|---|---|--|
| 500 h |  <p>04548 / 1</p> |  | | 40 | |
| a) - e) | | | | 52 | |
| i) 5 x  | | | 12645 | 52 | |
| k) 15 x  | | | 12645 | 55 | |
| h) 19 x  | | | C-12788 | 44 | |
| g) 6 x  | | | 12562 | 46 | |
| f) 7 x  | | 12562 | 48 | | |
| 1,000 h | h) 19 x  | | 10012 | | |
| f) g) 13 x  | | 10047 | | | |



The UV high-pressure lamps used, Ergoline Ultra 12645 (face tanner), are broadband radiators that can be operated with different wattages (approx. 240-520 W).



UV low-pressure lamps: Clean with plain water (damp cloth).

Maintenance



Maintenance

| 1,500 h | ⑤ | | 700 624 | 44 |
|----------------|----------|--|---------|--------|
| | ④ | | 800 399 | 44 |
| | ③ | | 800 389 | 46 |
| 3,000 h | ① (ViT) | | 702 605 | 52, 55 |



Filter panels: Clean with plain water (damp cloth).



Relamping / maintenance instructions

It is imperative that you, the owner and/or operator, check all components for any signs of wear which may occur through normal use.

- Observe the cleaning and maintenance schedule specified in the maintenance table on Page 38 to 42.
- Only replace UV low-pressure lamps with the original lamp type or with compatible lamps.
- Only replace UV high-pressure lamps with the original lamp type or with compatible lamps.

Should you require any assistance or need additional information, please call Global Service Division at 1-800-445-0624, Monday through Friday 8:00 a.m. - 19:00 p.m. CST



CAUTION – Damage due to improper maintenance!

Improper maintenance can cause the device to be damaged or to become unusable.

- Always comply with the specified maintenance intervals.
- Follow the cleaning instructions.
- If the maintenance intervals for the UV lamps are exceeded or incompatible UV lamps are installed, the share of harmful UVB radiation may increase. Sunburn and other skin damage may result.



Danger of burns from hot lamps and device parts

WARNING! If the tanning device was operated before being switched off and opened, lamps and housing parts may be hot.

- Before replacing lamps or other spare parts, wait until lamps and metal parts of the device have cooled down sufficiently.



Danger of pinching!

When opening and closing the tray, panels and covers, you can pinch your fingers.

- Avoid hinges.





UV low-pressure lamps, lower section

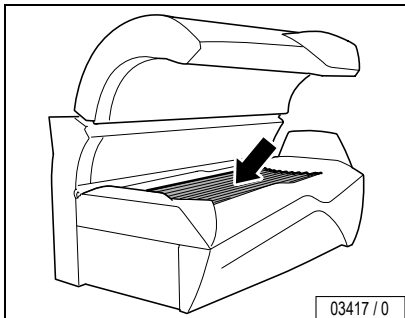
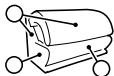

03417 / 0

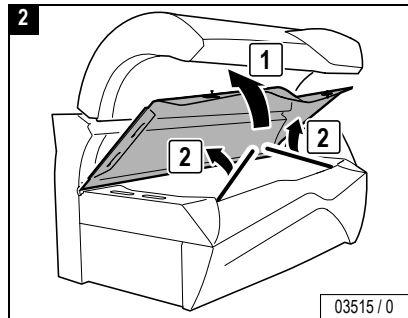

03515 / 0

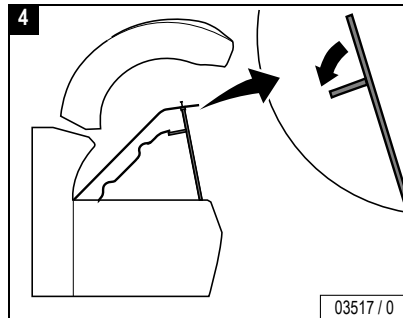

03517 / 0

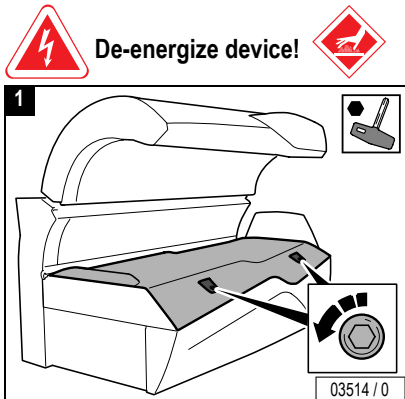

03514 / 0

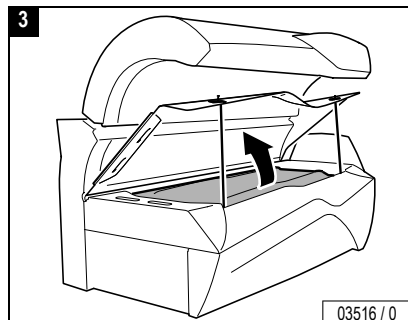

03516 / 0

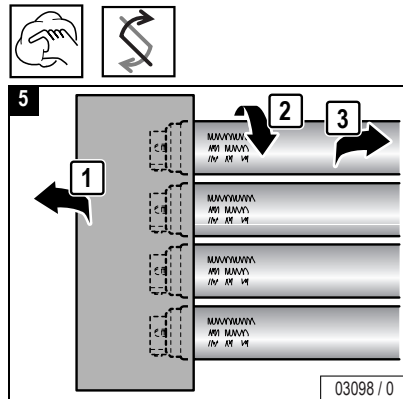

03098 / 0

...



Maintenance



De-energize device!



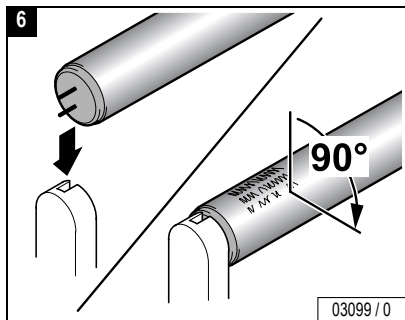

Close:

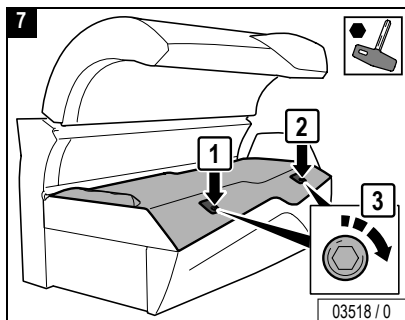

Maintenance 





UV low-pressure lamps, neck tanner

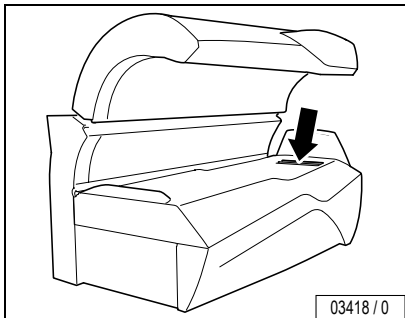
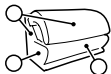

03418 / 0

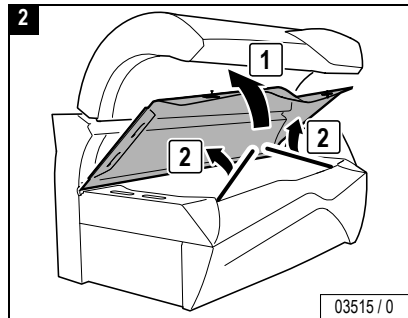

03515 / 0

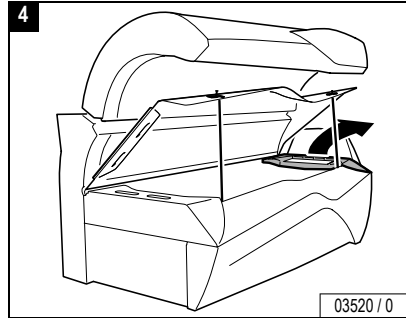

03520 / 0



De-energize device!

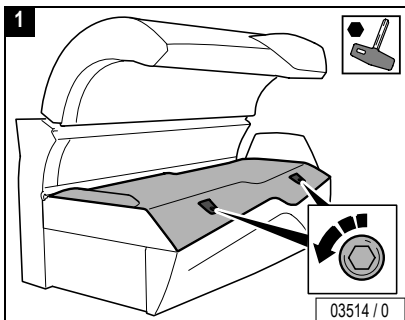

03514 / 0

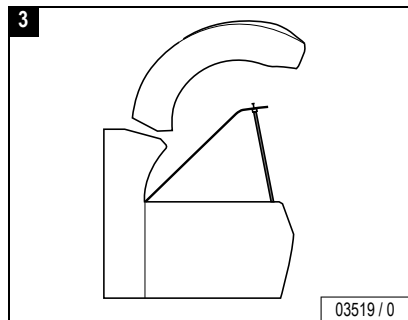

03519 / 0

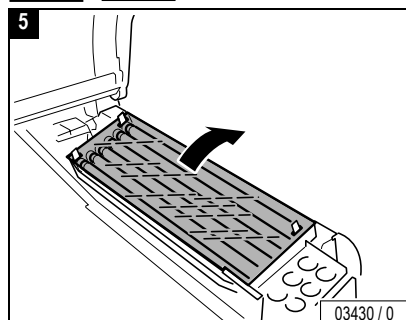

03430 / 0

...



Maintenance

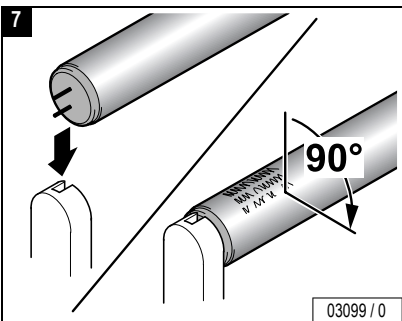
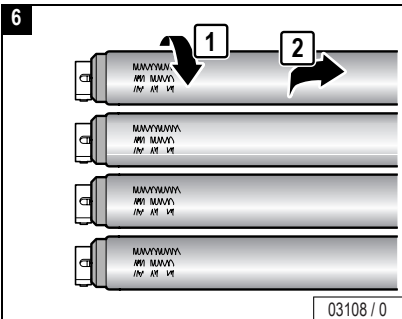

Close:

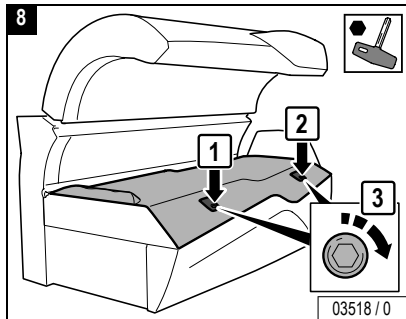

Maintenance 





UV low-pressure lamps, shoulder tanner

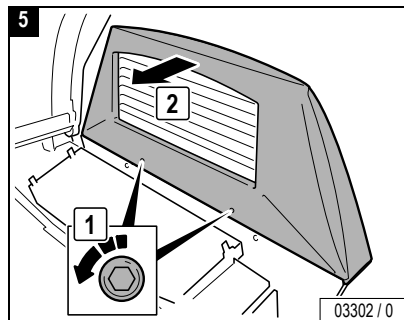
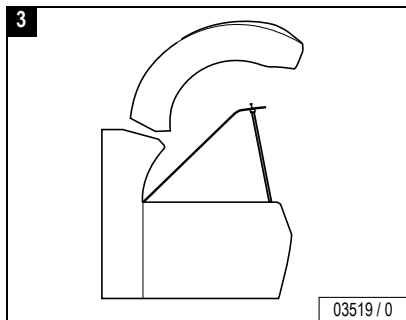
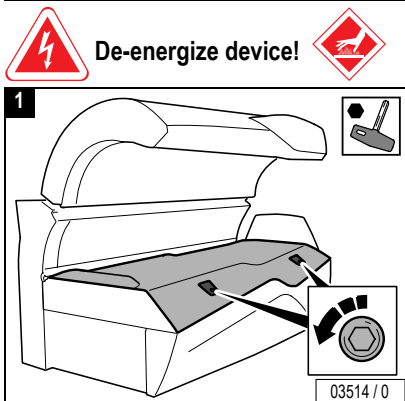
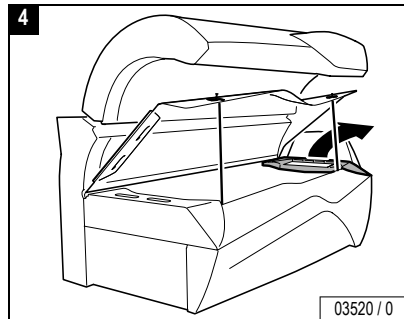
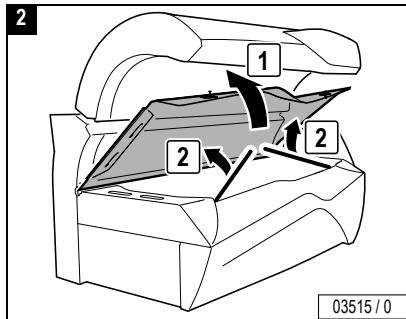
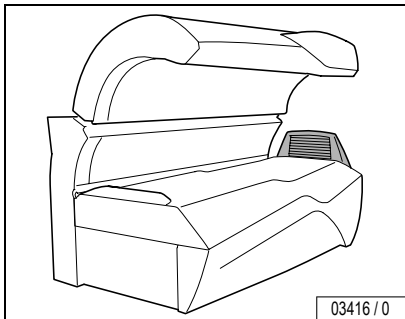
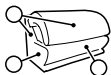

Maintenance

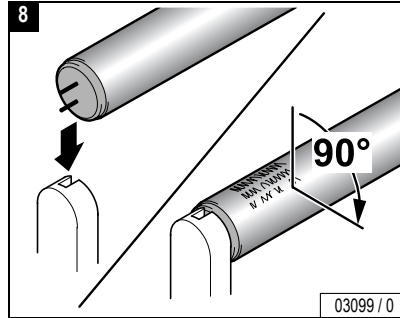
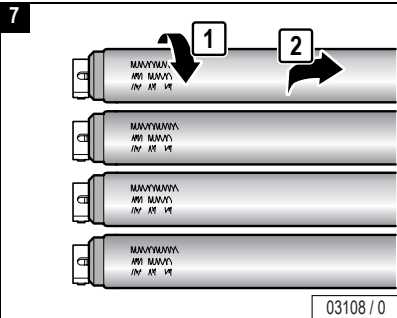
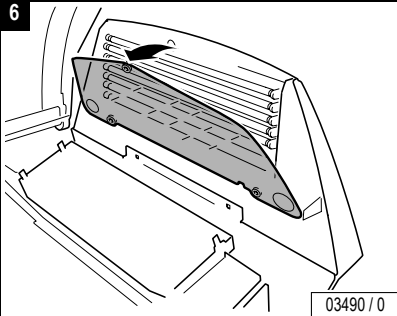

Close:

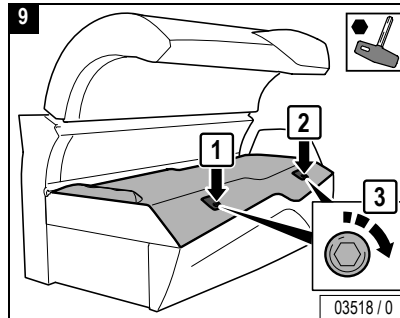

Maintenance 





Interior lighting, canopy

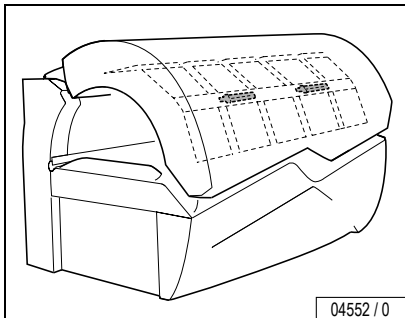
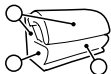

De-energize device!

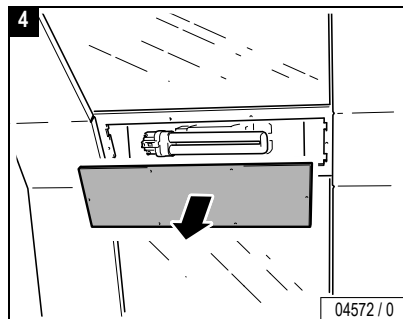
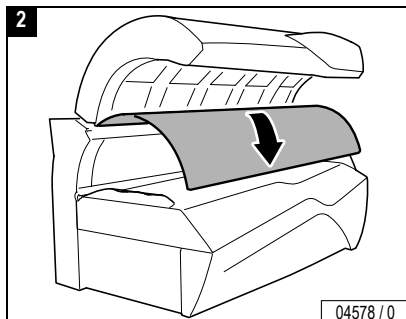
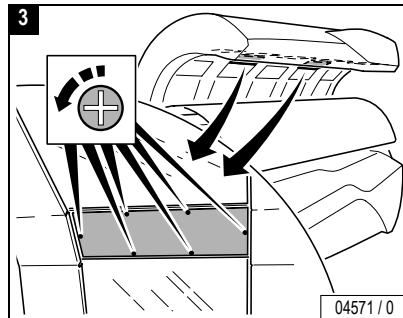
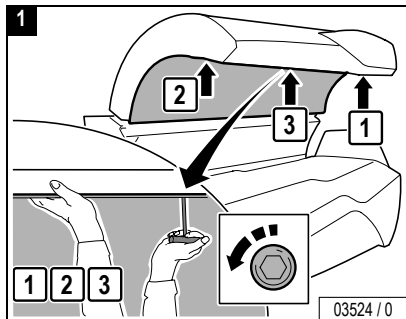

Danger of injury from the canopy panel!

WARNING! The canopy panel is heavy and falls down by itself after unscrewing the 3 screws.

- Support canopy panel.
- Loosen screws in the specified order.



Maintenance

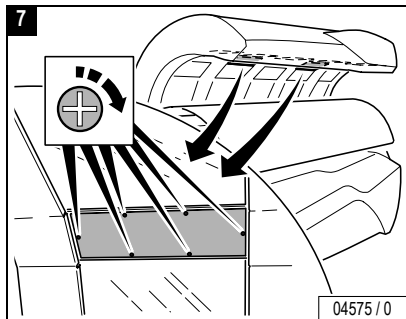
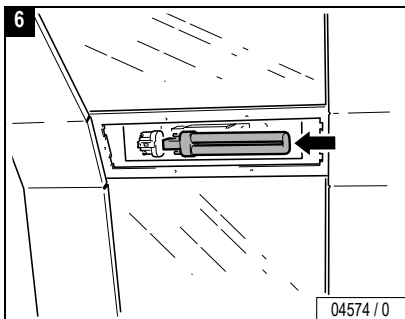
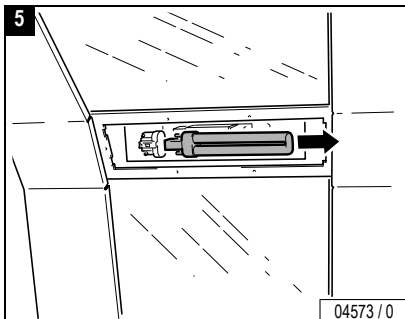

Close:

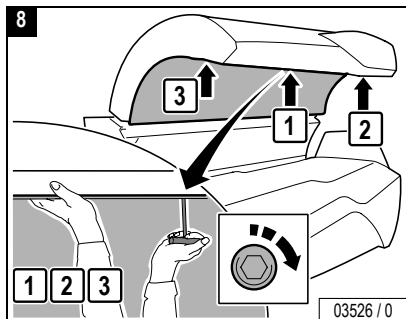

Maintenance 





UV high-pressure lamps, side section

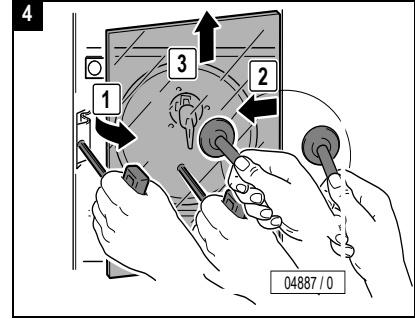
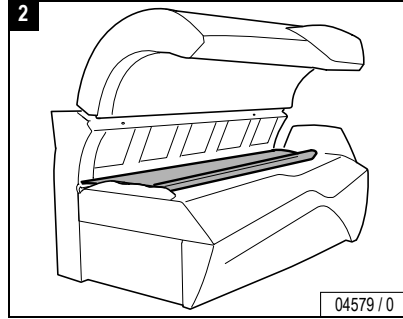
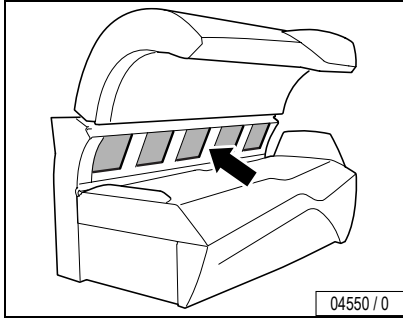
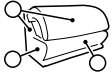

Maintenance



De-energize device!

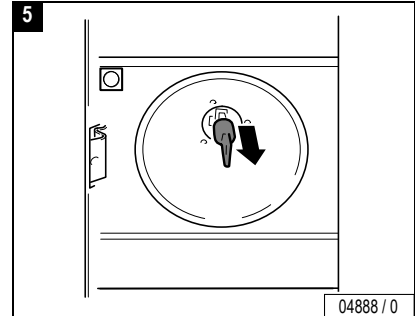
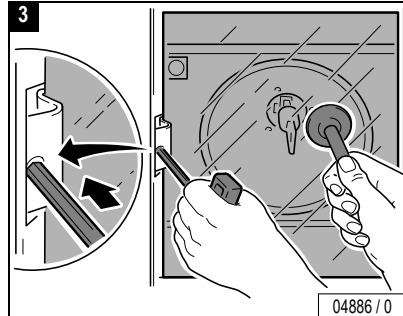
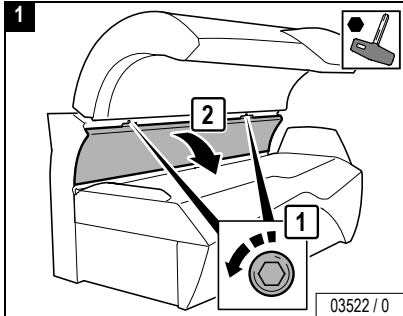

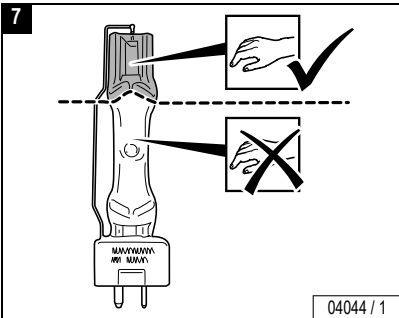
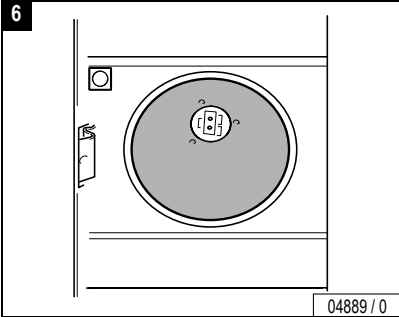

CAUTION!

Do not touch the glass bulbs of the UV high-pressure lamps with your bare fingers! Remove soiling thoroughly.

– Only touch new UV high-pressure lamp on the gripping surface – see Figures 7 and 8.

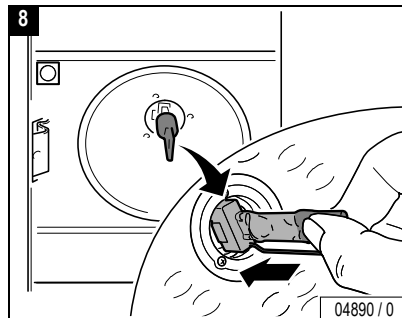

– Check safety switch:

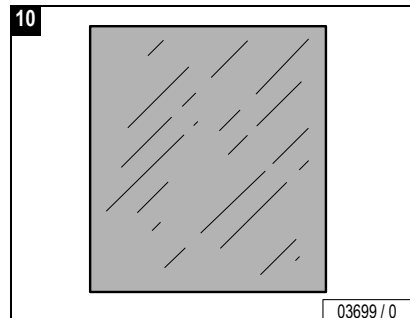
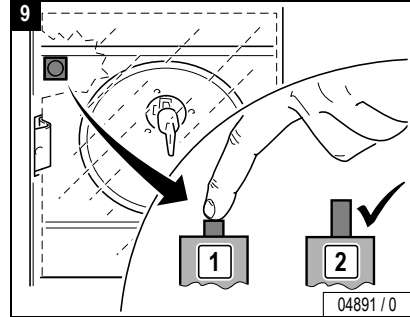

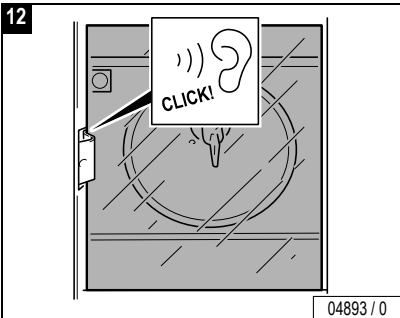
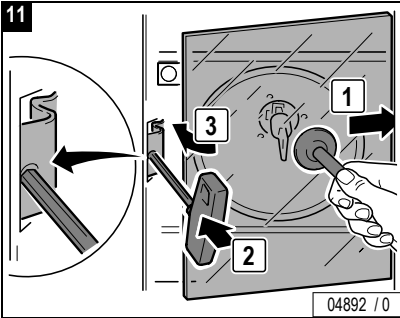

Close:

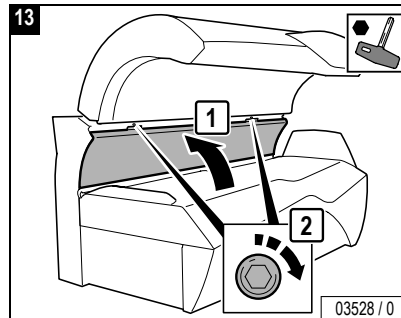

Maintenance





UV high-pressure lamps, canopy

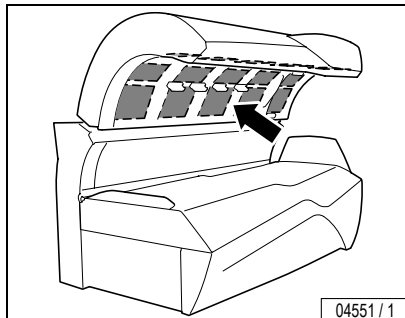
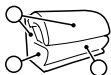

Danger of injury from the canopy panel!

WARNING! The canopy panel is heavy and falls down by itself after unscrewing the 3 screws.

- Support canopy panel.
- Loosen screws in the specified order.



De-energize device!

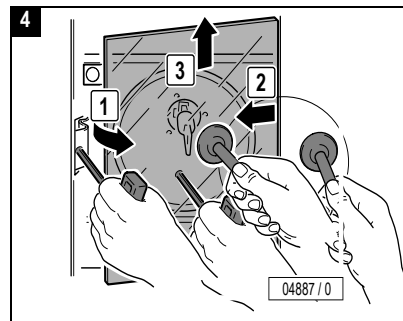
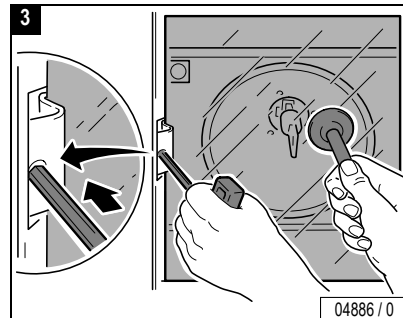
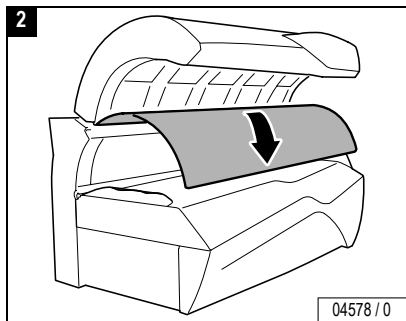
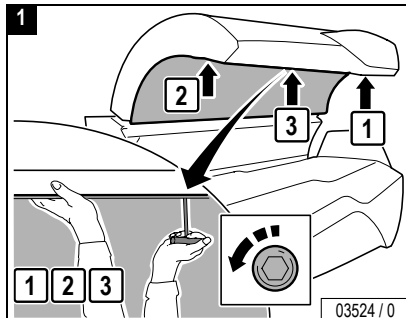

Maintenance

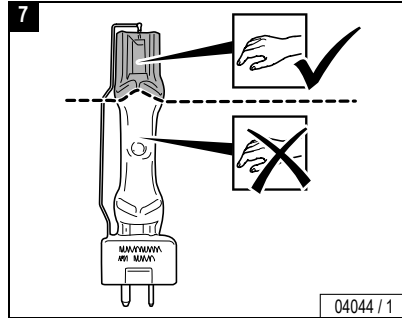
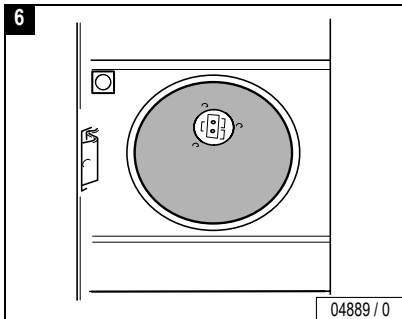
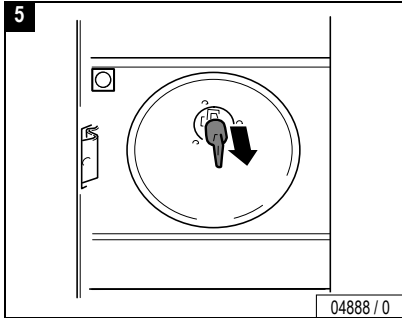

CAUTION!

Do not touch the glass bulbs of the UV high-pressure lamps with your bare fingers! Remove soiling thoroughly.

– Only touch new UV high-pressure lamp on the gripping surface – see Figures 7 and 8.

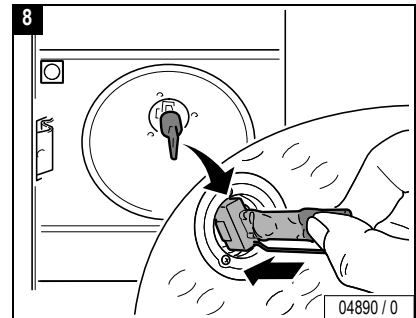

– Check safety switch:

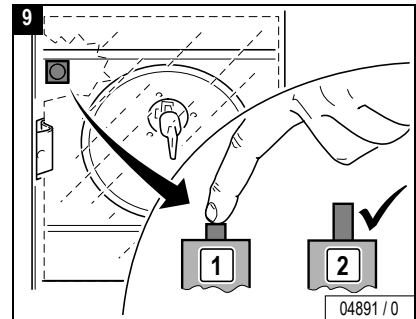

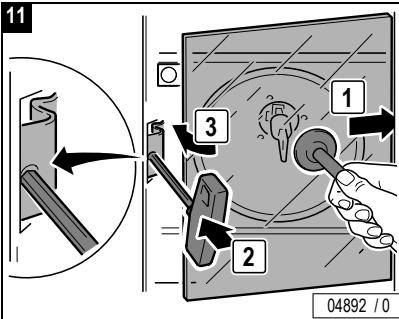
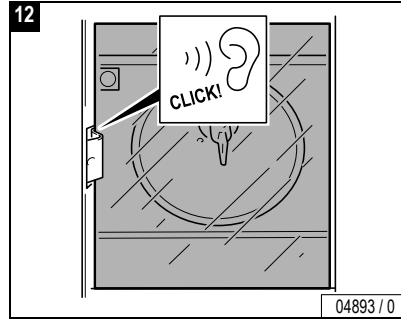
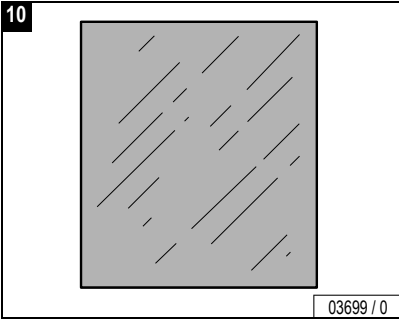

Close:

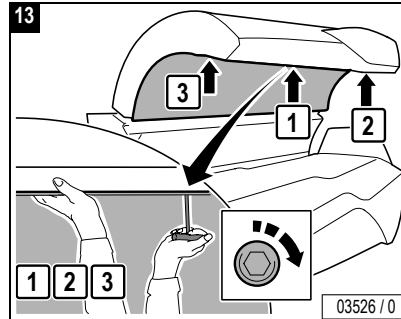

Maintenance 





Accent lights, canopy

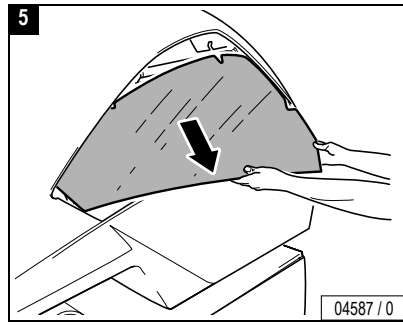
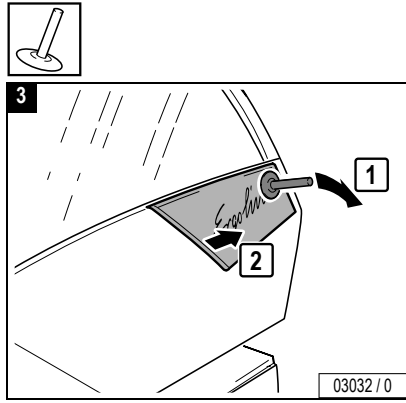
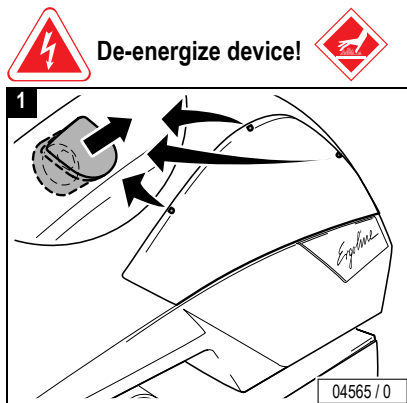
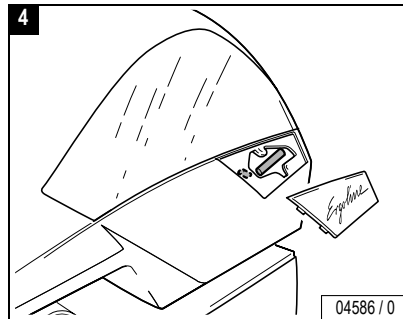
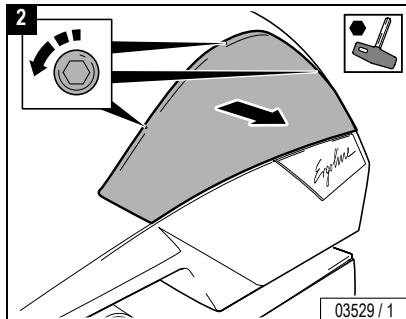
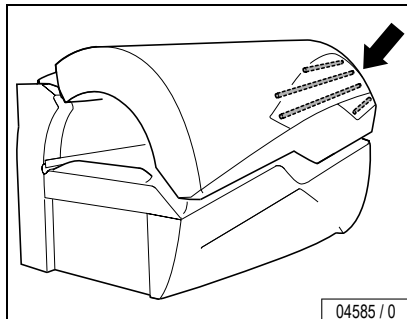
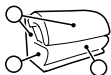

...

Maintenance



De-energize device!



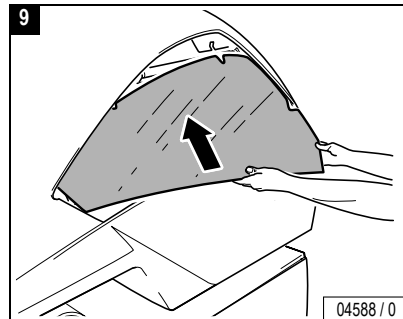
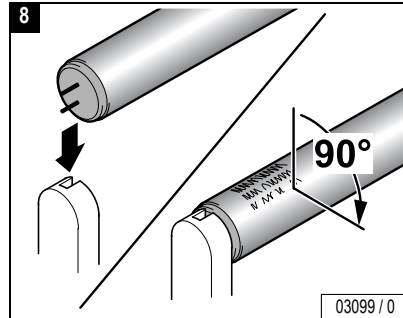
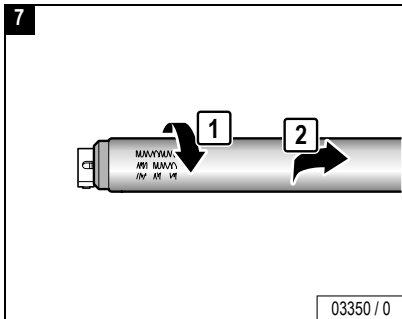
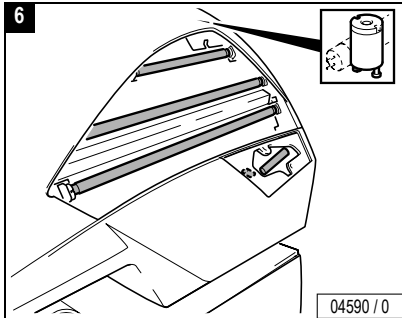

Close:

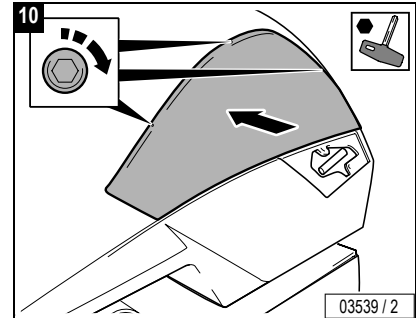

Maintenance

...



Maintenance

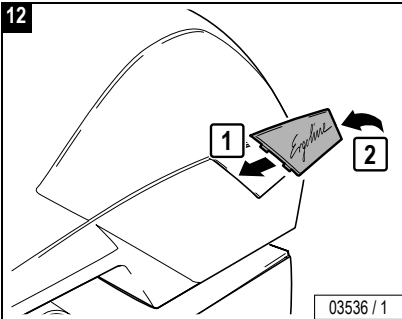
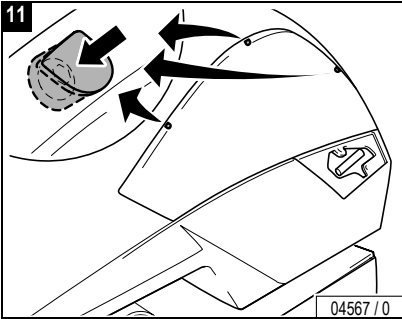



Accent lights, front panel

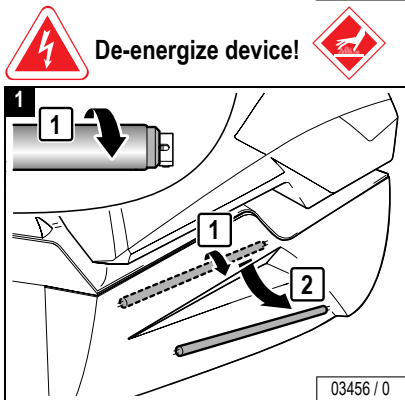
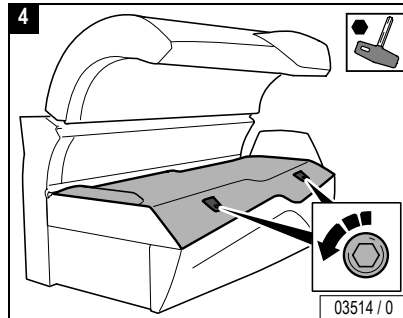
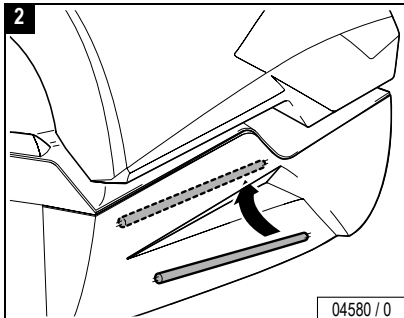
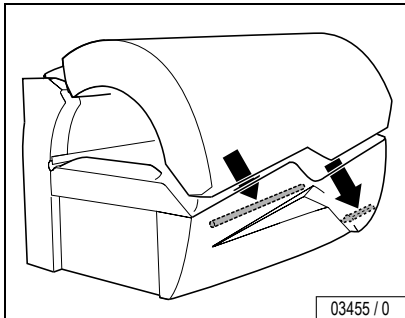
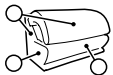

De-energize device!

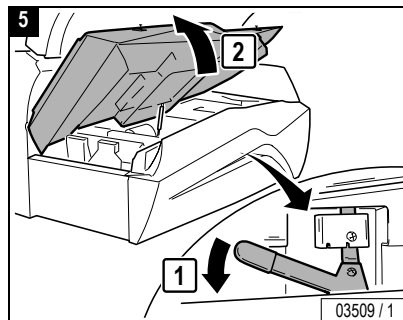
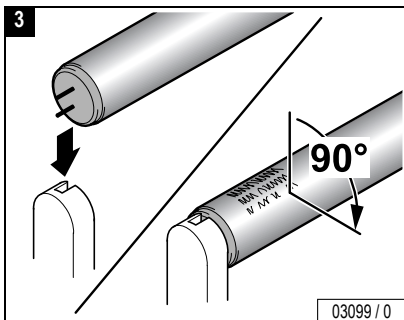

Maintenance 



Maintenance

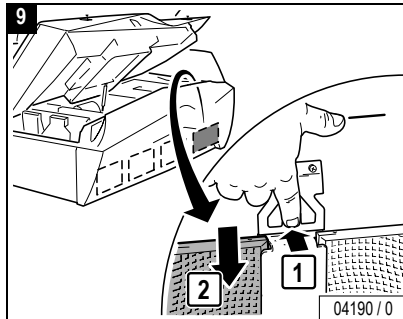
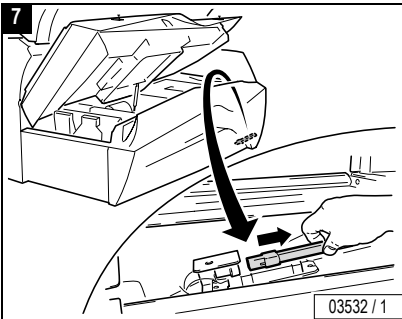
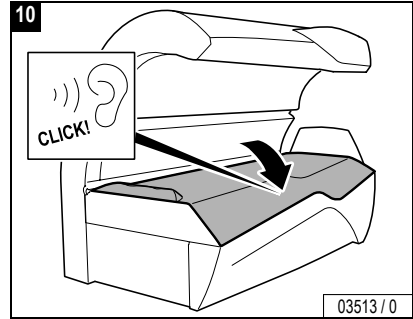
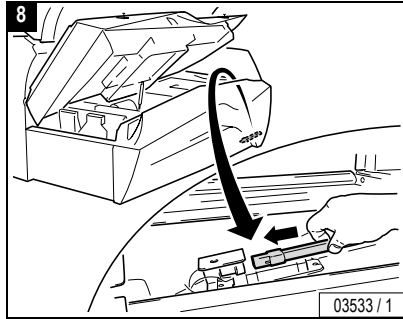
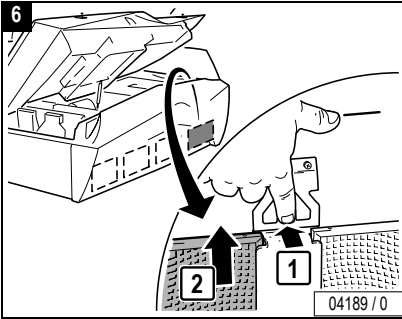

Close:

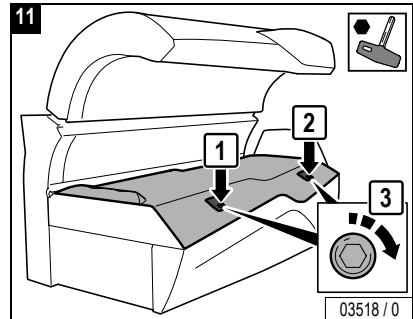



Lower section, filter

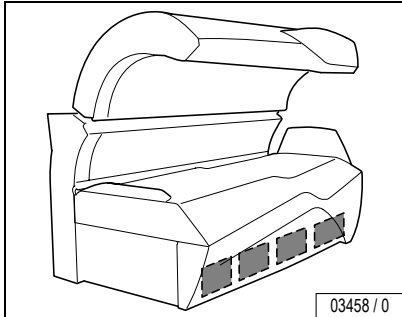
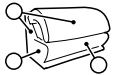

De-energize device!

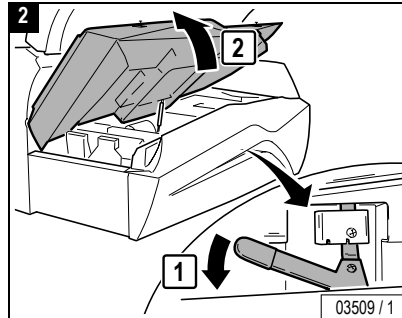
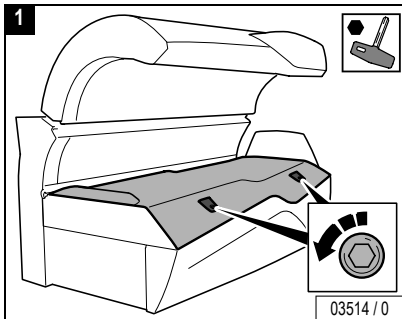

Hand-wipe lightly, dry or with water, or use a vacuum cleaner.

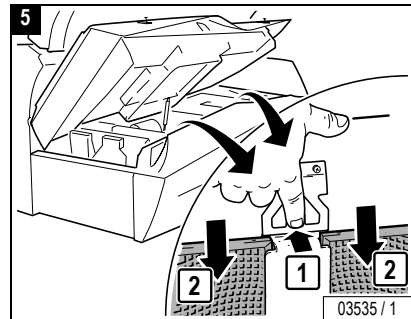
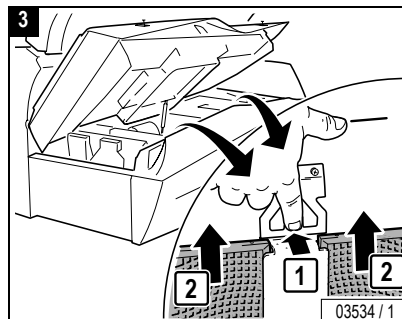
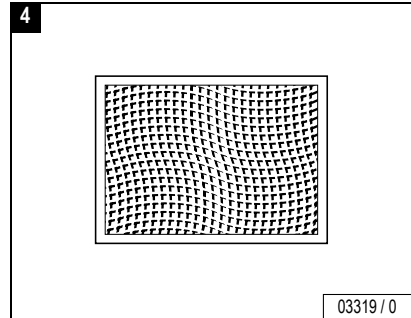

Maintenance



Maintenance

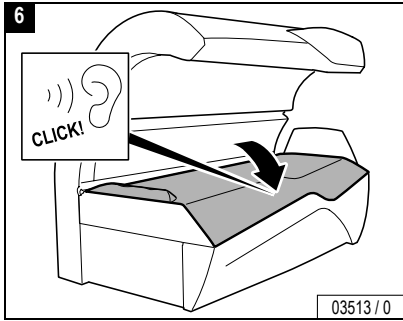

Close:

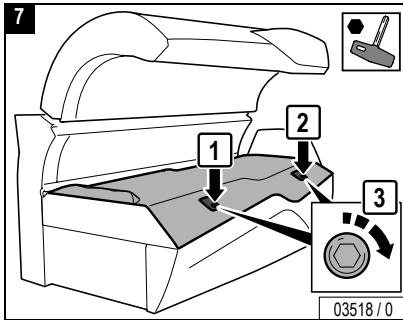



Canopy, filter mats

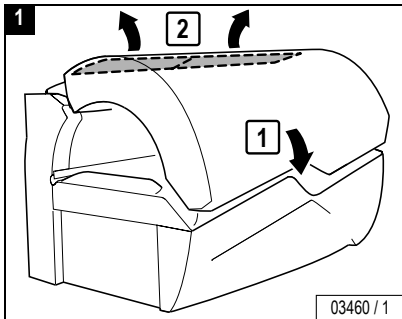
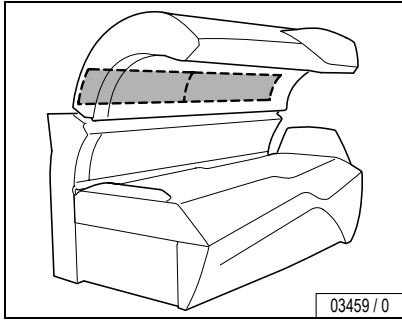
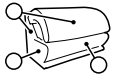

Rinse with water or replace.

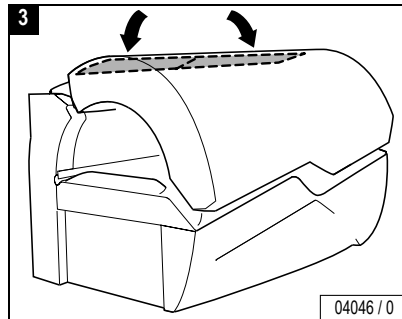
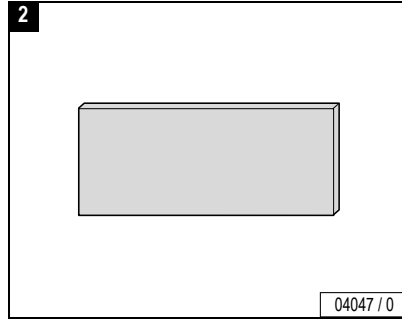



Shoulder tanner, filter mats

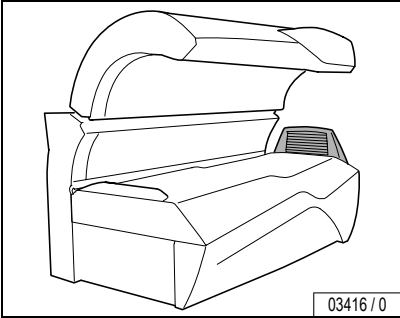
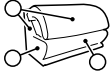

03416 / 0

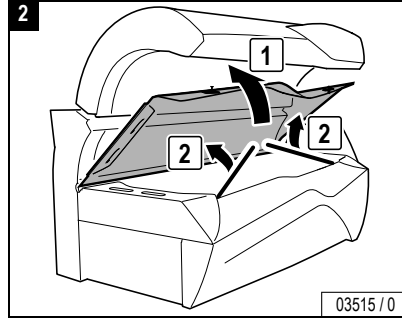

03515 / 0

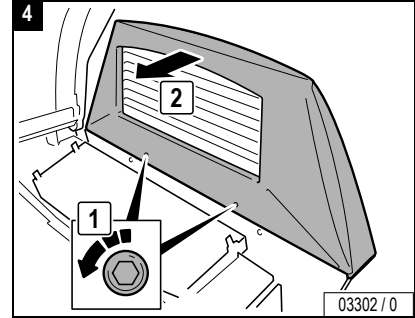

03302 / 0

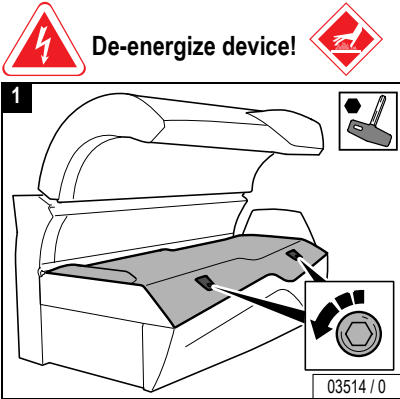

03514 / 0

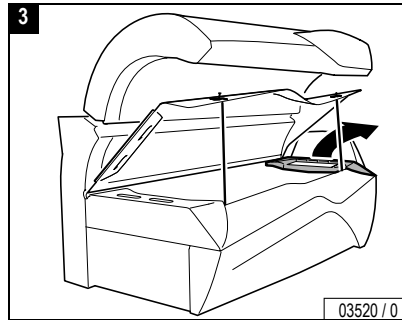

03520 / 0

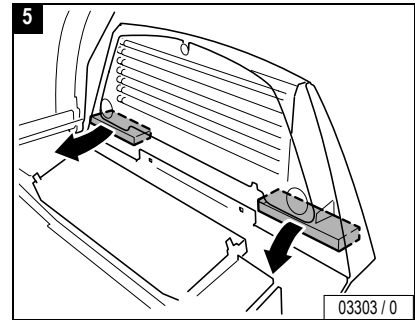

03303 / 0

...

Maintenance

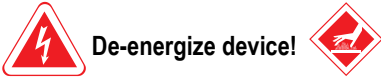

De-energize device!



Rinse with water or
replace.

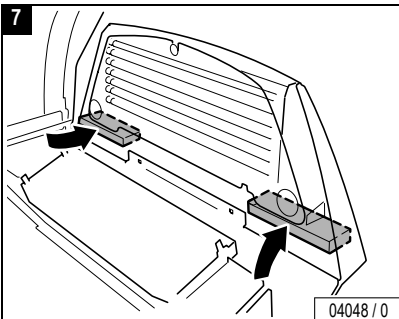
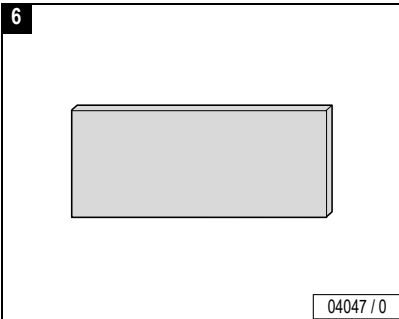

Close:

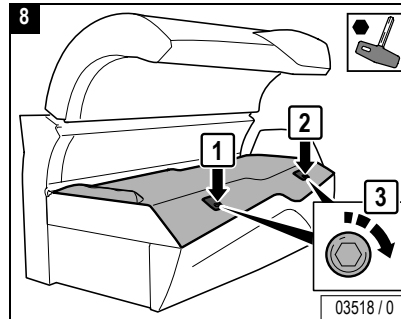



Air Condition, condensate and filter mats

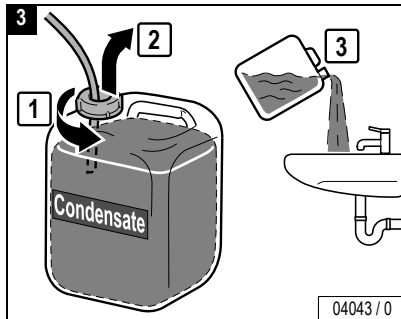
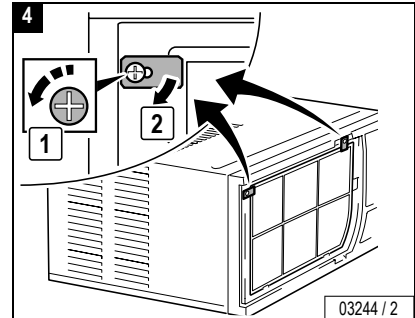
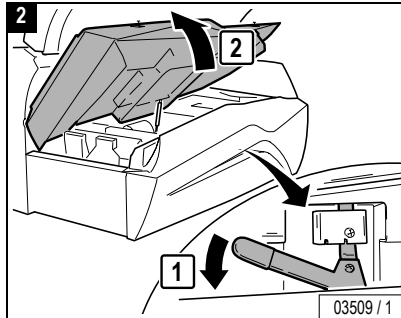
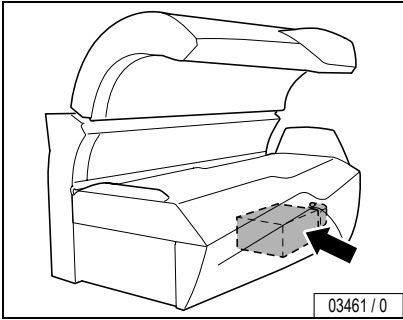
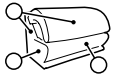

Clean carefully (vacuum or wash) or replace.

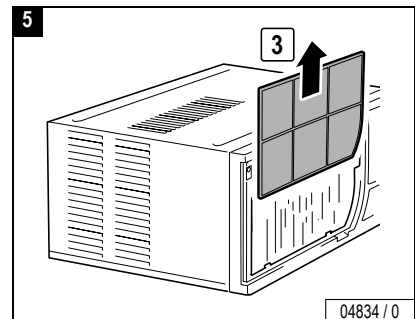

Maintenance



De-energize device!

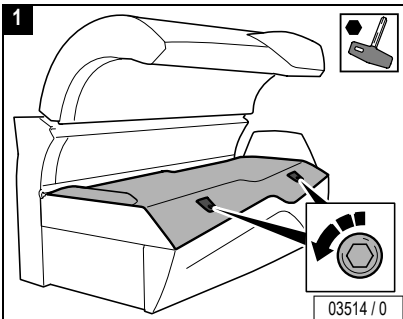

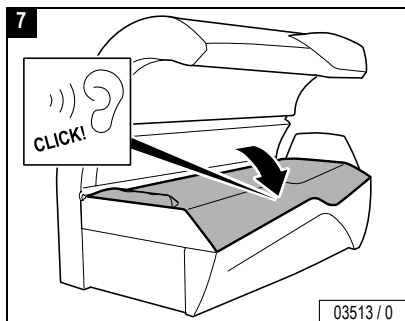
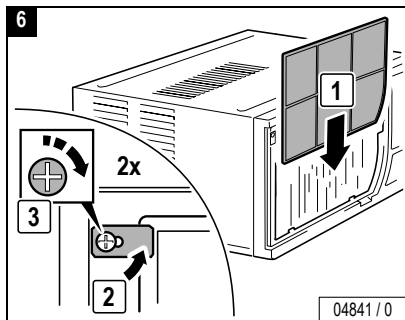

Close:

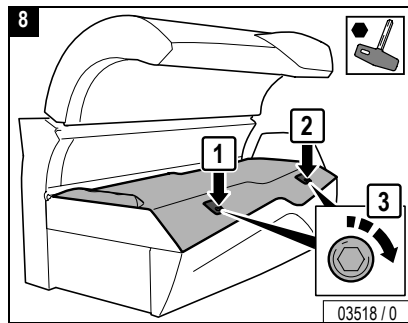

Maintenance 







Changing presettings with the control panel

The setting mode enables you to call up operating states and make alterations to current settings. If VoiceGuide is included with the device, you can also listen to the explanations on the preadjustments.

Changing to Presetting mode

- Press the buttons - and + simultaneously for at least five seconds outside a tanning process.
-  appears in the display.
- Enter the code (see Page 71).
- Press the START/STOP button four times when you run the Presetting mode for the first time.
-  briefly appears in the display, then  (Function 1) and the presetting value are displayed alternately (see column "On delivery").
- By pressing the + button you scroll up to the next function (from -01- to -19-).
- By pressing the – button you scroll down to the next function (from -19- to -01-).

Changing presettings

Increase the preset value:

- Press and hold the START/STOP button while simultaneously pressing the + button.

Decrease the preset value:

- Press and hold the START/STOP button while simultaneously pressing the – button.

Reset to the last value set:

- Press the START/STOP button.

Reset to the delivered state:

- See function .



Note:





The sunbed will automatically return to 'idle' mode 30 seconds after the last button was pressed.

The presettings are listed beginning on Page 73.





Defining a code

- Select Function .
- Press the START/STOP button for 3 seconds until  appears.
- Press the desired buttons consecutively:
- Press the buttons in the same sequence when  appears again.
-  appears in the display. The set code has been saved.
- Please note the code for Customer Service.

If you know the old code, you can define a new code at any time.





Changing presets with a hand-held unit

Some data can also be displayed and changed with a commercially available hand-held unit (e.g. from Palm). For this purpose you require special software (available in German and English), which you can download at www.sunergoline.com. The operating manual for this software is also available at the same website.



Caution!

The code for access via the infrared interface is preset in the software of the hand-held unit, and can therefore be used with any unit. Anyone, who downloads the software from the Internet can access the unit date with a hand-held unit. Please note that Customer Service changes the preset access code during initial start-up – see software operating manual. Please note the new code for future use!

This code is independent of the access code for the presets via the control panel.



Note:

Please read the operating manual for the software for instructions on how to display or change data with a hand-held unit.

Information on operating the hand-held unit is contained in the manufacturer's documentation.

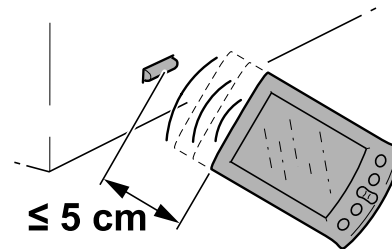

IR Function

04002 / 0



| No. | Description | on delivery | Values from-to |
|-----|---|-------------|-------------------|
| | Total number of operating hours | | 0 → 9999 |
| | Remaining operating time of UV low-pressure lamps (hours) | | 500 → 0000 |
| | Remaining operating time of UV high-pressure lamps (hours) | | 500 → 0 |
| | Remaining operating time of shoulder tanner (hours) | | 500 → 0 |
| | Remaining operating time of filter mats (hours) | | 50 → 0 |
| | Air conditioning operating hours | | 0 → 9999 |
| | Decorative lighting operating hours (minutes) When the maximum value is exceeded: Display = continuous operation | | 1 → 1440 |
| | Fan run-on time (minutes) | | 3 → 10 |
| | To set the time | | 1 → 23 01 → 59 |

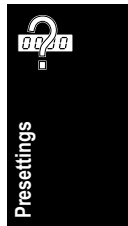





| No. | Description | on delivery | Values from-to |
|-----|--|-------------|----------------|
| | To reset the device to ex-works setting (all functions) | | |
| | To set the access authorisation code to enter setting mode (see Page 71) | | |
| | Adjust volume for voice output (VoiceGuide) | | 7 → 63 |
| | Adjust volume for music output (Sound System) | | 7 → 63 |
| | Ambient temperature setpoint value (°C) | | 15 → 30 |
| | Recycle air during fan run-on time (+ = on / - = OFF) | | |
| | Lower temperature limit of air conditioner | | 15°C → 25°C |



Troubleshooting

In the case of a fault, fault codes appear on the display to simplify localizing of the fault cause:

- If a fault occurs, the fault code flashes in the display.
- If several faults occur, the fault messages are displayed alternately.
- On devices with : The text messages on the current fault messages of the device can be displayed in the fault mode by pressing the  button.
- The fault remedy is acknowledged by pressing the  button.

If the fault cannot be eliminated, inform Customer Service:



Global Service Division

#1 Walter Kratz Drive

Jonesboro, Arkansas 72401

 (800) 445 0624



Trouble-
shooting



| Error | Meaning | Correction |
|-------|---|-------------------------------|
| | Full condensation tank (only when using an original condensate container) | Empty condensation container. |
| | Fault in condensation pump | |
| | Temperature sensor for heating (air conditioner) | |
| | Temperature sensor for cooling (air conditioner) | |
| | Fault in temperature sensor for UV low-pressure lamps | |
| | Temperature sensor for room | |
| | Panel switch for shoulder tanner | |
| | Air-vane switch does not switch on with fan running | |
| | Air-vane switch does not switch off 1 minute after fan switches off | |
| | Fault in front face tanner | |





| Error | Meaning | Correction |
|-------|---|------------|
| | Fault in centre face tanner | |
| | Fault in face tanner rear | |
| | Fault in face tanner side section | |
| | Panel switch on decorative panel on canopy | |
| | Panel switch of acrylic glass panel on sunbed base/side section | |
| | Emergency switch-off time exceeded | |
| | I ² C bus fault | |
| | Switching error in series circuit of safety switch | |
| | Auxiliary controller | |
| | Heating controller | |





| Error | Meaning | Correction |
|-------|-----------------------------------|------------|
| | Face tanner controller | |
| | Speed control 1 | |
| | Speed control 2 | |
| | Audio amplifier | |
| | Channel selection | |
| | Real-time clock | |
| | Parameter memory | |
| | Incorrect equipment of controller | |



Index

A

Accent lights
 Operation 24
 Replacing 58, 61, 62
 Acrylic glass panels 14
 Air condition
 Condensate, filter mat 68
 Operation 28

B

Bed tolerance in room 36
 Body tanner, operation 26

C

Channel, operation 33
 Children 9
 Circuit breakers 37
 Cleaning schedules 38
 Code
 Defining a code with hand-held unit... 72
 Defining a code with operating panel . 71
 Condensate, air condition 68
 Contact 19

D

Deenergizing device 37
 Disposal of lamps 16

E

Equipment 13
 Error codes 75
 Export 13
 Exposure schedule III
 Eye injuries 8

F

Face tanner, operation 25
 Fan delay 22
 Fault codes 75
 Filter mats
 Air condition, cleaning/replacing 68
 Canopy, cleaning/replacing 65
 Shoulder tanner, cleaning/replacing... 66

Filter panels, cleaning 54, 57
 Filter, lower section, cleaning 63
 Frequency 35
 Fusing 35

G

Global Service Division II

H

Hand-held unit, changing presettings 72

I

INFO, operation 32
 Intended use 8
 Interior lighting 50

L

Label II
 Load, maximum 36
 Long-term consequences 9

M

Maintenance schedules 39
 Minors 9

N

Neck tanner, lamps 46

O

Operator, important information 8
 Order numbers 39, 40, 41
 Overview
 Maintenance 38
 Operation 20

Index

| | | | | | |
|---------------------------------------|--------|------------------------------|-----|--------------------------------------|----|
| P | | Symbols | 10 | U | |
| Palm, changing presettings | 72 | Cleaning | 12 | UL Standard | 13 |
| Plastic | 15 | Draining | 12 | UV high-pressure lamps | |
| Power consumption | 35 | Ergoline key | 10 | Canopy | 55 |
| Powerinput | 35 | Filter panel | 10 | Side section | 52 |
| Preparation time | 22 | Filter/filter mat | 12 | UV lamps, maintenance schedule | 41 |
| Presettings | 70 | High-pressure lamp | 10 | UV low-pressure lamps | |
| Table | 73 | Hot surface | 10 | lower section | 44 |
| R | | Low-pressure lamp | 10 | Neck tanner | 46 |
| Relamping instructions, general | 43 | Press button | 11 | Shoulder tanner | 48 |
| Room temperature, maximum | 36 | Replacing | 12 | V | |
| S | | Safety switch | 11 | Ventilation | 17 |
| Safety information | III, 8 | Starter | 10 | Voice Guide, operation | 31 |
| Settings at start | 23 | Visual inspection | 12 | Voltage | 35 |
| Shoulder tanner | | T | | Volume, operation | 34 |
| Filter mats | 66 | Tanning instructions | 16 | | |
| Lamps | 48 | Tanning times | III | | |
| Operation | 27 | Technical data | 35 | | |
| Skin types | 17 | Temptronic | | | |
| Spare parts | 14 | Condensate, filter mat | 68 | | |
| Start of tanning session | 22 | Operation | 28 | | |
| Sun screen | 17 | Termination of tanning | 23 | | |
| Surround cooling, operation | 28, 29 | Troubleshooting | 75 | | |
| | | Type label | II | | |

Warranty

SUN Ergoline – Limited Warranty

SUN Ergoline warrants its products to be free from defects in materials and workmanship under intended normal use as described in the unit's Operation and Instruction Manual, for a period of three (3) years from date of sale.

This Limited Warranty applies only to the original purchaser of the equipment through SUN Ergoline or its authorized dealer or distributor, and is not transferable.

SUN Ergoline obligations under this warranty are limited to repair or replacement of any defective part without charge for that part to the original purchaser, with the following exceptions:

- A. Fluorescent lamps are warranted against defects for a period of thirty (30) days from date of sale.
- B. Only parts obtained through SUN Ergoline, its authorized dealers or distributors may be used. Transportation costs for parts shipped to the consumer and the return of defective parts to SUN Ergoline are not included.
- C. Labor will be furnished without charge for ninety (90) days from date of purchase only. All labor and related charges must be authorized by SUN Ergoline prior to start of repairs, and must coincide with SUN Ergoline established rates and time allotment policy.
- D. Acrylic: Refer to Manufacturer's Acrylic Warranty Policy.

It is imperative that the original customer completes and returns the enclosed warranty card within 10 days after purchase to insure valid registration and coverage for potential claims.

If the warranty card is not registered, proof of purchase from SUN Ergoline or its authorized dealer or distributor will be required prior to any consideration on warranty claims. This could result in service delays.

This warranty is extended to the individual or legal entity, whose name appears on the warranty registration card filed with SUN Ergoline, or whose name appears on the original sale document and may not be transferred to any other individual or legal entity.

This warranty does not apply to any failure of the product, or any parts of the product due to alterations, modifications, misuse, abuse, accident, improper maintenance, improper installation, acts of God or if the serial number on the product has been removed, altered or defaced. Adequate packaging must be used for returned goods to prevent freight damage.

There are no warranties which extend beyond the description on the face hereof. There is no express or implied warranty of fitness or merchantability.

The remedies provided in this limited warranty are the exclusive remedies provided to the purchaser by SUN Ergoline and are provided in substitution of all other remedies. Consequential and incidental damages are excluded.

No person, firm or corporation is authorized to obligate SUN Ergoline for any liability in connection with the sale or use of these goods.

Warranty

Limited Acrylic Warranty

SUN Ergoline warrants its acrylic sheets to be free from defects in material and workmanship, under intended normal use, for a period of one (1) year from date of sale of the tanning bed. Due to the tanning lotions, cosmetics, disinfectant and improper cleaners used on tanning surfaces that cannot be controlled by SUN Ergoline, after the first thirty (30) days of warranty period. Acrylic will be subject to a prorated cost to the consumer on breakage.

SUN Ergoline obligations do not include transportation charges on replacement acrylic.

SUN Ergoline assumes no liability for the cost of removing defective sheets or installing replacement sheets, nor for damage to persons or property.

To make a claim, contact an authorized dealer or distributor of SUN Ergoline or Global Service Division with the model number, the serial number, and the date of purchase of the bed in which the acrylic will be used.

There are no warranties which extend beyond the description on the face hereof. There is no express or implied warranty of fitness or merchantability.

The remedies provided in this limited warranty are the exclusive remedies provided to the purchaser by SUN Ergoline and are provided in substitution of all other remedies. Consequential and incidental damages are excluded.

Global Service Division

#1 Walter Kratz Drive
Jonesboro, Arkansas 72401

☎ (800) 445 0624

Warranty Claims

Policy & Procedures

1. When to file a Warranty Claim:

In the event that your tanning system is not functioning properly under intended normal use as described in the unit's Operation an Instruction Manual, you may then have established cause to file a Warranty Claim.



NOTE: Both the tanning system and legal registered owner must meet the criteria established under SUN Ergoline Limited Warranty as described in this manual before any Warranty Claim will be considered.

2. Where to call to place a Warranty Claim:

SUN Ergoline is supported nationwide by an extensive dealer/distributor network through whom the majority of our units are sold. These dealers/distributors are required by contract to stock sufficient parts to meet the various warranty and nonwarranty needs of their customers.

Therefore, in order for you to properly file a Warranty Claim, you must locate the name and phone number of the dealer/distributor through whom you purchased your unit. Normally this information can be easily located either on your paid invoice or other proof of purchase documentation that you received when taking delivery of the unit.

Next, notify the dealer/distributor of the serial number, model number and date unit was purchased. This will initiate the Warranty Claim process.

Upon determination of the problem, your dealer/distributor can then supply you with the part(s) and proper instructions to return your unit to work-

ing order.

Each dealer/distributor has their own internal procedure for handling Warranty Claims and credits.

NOTE: SUN Ergoline, the manufacturer, does not involve itself in the direct handling of a Warranty Claim except where mitigating circumstances apply and where required by law.

Parts Warranty Claim/Credit Review

1. Customer calls SUN Ergoline and notifies the Service Department of problem
2. SUN Ergoline Service Department determines course of action.
3. SUN Ergoline ships part and R.A.I. to customer freight collect and bills customer on net30 basis for part only.
4. Customer, within 15 days of receiving new part, returns defective part to SUN Ergoline along with R.A.I.
5. Upon receipt of defective part and R.A.I., SUN Ergoline issues customer a credit invoice which offsets original bill. Customer's account is returned to zero balance concerning this claim.



NOTE: If part returned to SUN Ergoline proves to be operational and not defective, or if product code numbers on part do not correspond with individual unit date on file with SUN Ergoline, then a 30% restocking fee will be charged in addition to the retail purchase price of part.

Warranty

Acknowledgment of the Agreement is not required for acceptance of the foregoing stipulations.

Labor Warranty Claim/Credit Procedures

SUN Ergoline furnishes labor without charge for a period of 90 days from date of purchase. All labor and related charges must be authorized by SUN Ergoline prior to start or repairs, and must coincide with SUN Ergoline established rates and time allotment policy.

Please contact our Service Department for authorization and billing procedures.

Limited Lifetime Warranty

SUN Ergoline warrants specific individual components of the Competition Tanning Systems against defects in materials and workmanship for the life of the product. Coverage is limited to units purchased after November 1, 1994.

This warranty is restricted by the following components only:

- Steel Back Panels
- Structural Steel Frame Components
- Exterior Steel Body



NOTE: Components are warranted on an individual basis and not as they may effect the complete product.

Warranty coverage does not include cosmetic abnormalities such as scratches, nicks, dents, oxidation of paint or other cosmetic changes that

do not interfere with the designed function of the unit.

This warranty does not include failure of the product due to alteration, modifications, misuse, abuse, improper maintenance, improper installation or repair.

This warranty is not transferable and is only applicable to the original purchaser named on a completed and registered warranty record at SUN Ergoline headquarters.

SUN Ergoline obligations do not include transportation charged on the shipping of new components to the customer or on the return of defective components of the manufacturer. All freight charges must be paid by the customer.

There are no warranties which extend beyond the description on the face hereof. There is no express or implied warranty of fitness or merchantability.

The remedies provided in this limited warranty are the exclusive remedies provided to the purchaser by SUN Ergoline and are provided in substitution of all other remedies. Consequential and incidental damages are excluded.



Notice: Any misuse, abuse, modification, alteration, improper maintenance, improper installation, etc. of this product or its intended use will subject said party to direct responsibility and liabilities for any and all consequences resulting from such action. Furthermore, such actions will void all warranties and may relieve SUN Ergoline of any liabilities relating to said product.



NO POSTAGE
NECESSARY
IF MAILED
IN THE
UNITED STATES

BUSINESS REPLY MAIL
FIRST-CLASS MAIL PERMIT NO 295 JONESBORO AR

POSTAGE WILL BE PAID BY THE ADDRESSEE

SUN ERGOLINE, INC.
#1 WALTER KRATZ DRIVE
JONESBORO, AR 72401

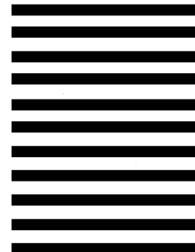

Separate here



SUN
Ergoline

Ergoline

soltron

SUN
Ergoline

Ergoline

soltron

(A) WARRANTY REGISTRATION

Please complete the warranty section below. To validate and insure proper coverage, card must be completed and returned within ten (10) days of the date of purchase.

_____/_____/_____
Name of Purchaser Date of Purchase

Street Address or P. O. Box

City State Zip

()

Phone Number with area code

Company unit purchased from and amount paid.

Name of Business (if applicable)

Circle Answers: **Sex:** Male Female

Age: 18-29 30-39 40-49 50-59 60+

Annual Household Income:

up to \$15,000 \$15-30,000
\$30-50,000 over \$50,000

Residence: Own Home Rent Other

If you experience any difficulties obtaining replacement parts from your distributor, please call Sun Ergoline at 800-643-0086, choose option 5.

SE Year & Model #

SE Serial #

Separate here

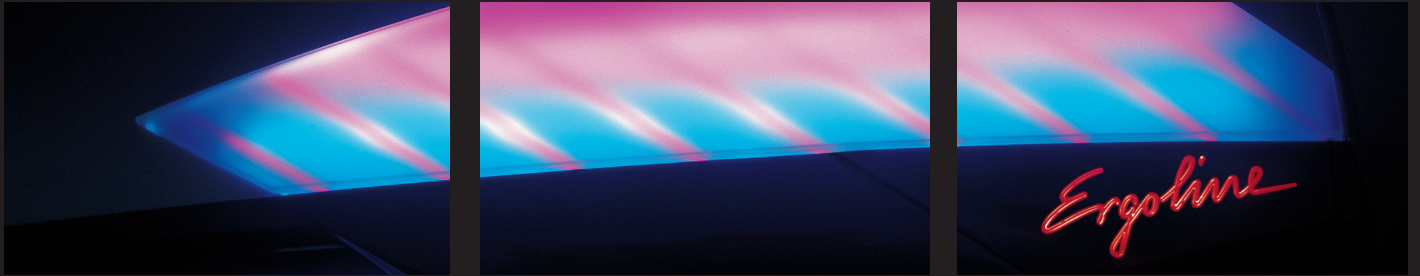

SUN ERGOLINE INC. · #1 Walter Kratz Drive · Jonesboro, Arkansas 72401 · Phone: 1-800-643-0086 or 870-935-1130 · Internet: www.sunergoline.com